

TASHKOO

Weatherproof Industrial Telephones

Heavy Industry Solutions

- ✓ Analogue
- ✓ SIP / VoIP
- ✓ GSM
- ✓ 3G

info@tashkoo.com

www.tashkoo.com



Full Keypad, With Display



- Vandal resistant handset and cord
- Weather proof protection IP66-IP67
- Full keypad with memory, 0-9 buttons can be programmed as speed dial button.
- "LR" button for last number redial
- "R" for flash recall
- "M" for muting
- Wall or top of pole mounting, simple installation
- Inductive coupler fitted as standard for hard of hearing
- Phone line powered (Analogue)
- External power supply or PoE (SIP-VoIP)
- RJ45 port for SIP phone
- CE compliant

TASHKOO offered weatherproof telephones are fully contained within a corrosion resistant cast aluminum weatherproof case with a door providing complete protection against dust and moisture ingress, resulting in a highly reliable product with a long MTBF.

The unique robust handset is manufactured from moulded Bulk Molding Compound and designed specifically to withstand arduous use in all environments, armoured cord to provide additional resistance to vandalism or heavy industrial use. These Weatherproof Telephones are designed for use by the railways, power stations, the armed services and heavy industry which require very reliable telephony under adverse conditions. Powdercoat finish available in Yellow or Grey, durable and resistant to discolouration yet easily cleaned. Installation is simple and quick via M20 cable glands on to fast-fit connectors which are accessed without the need for dismantling the telephone body.

Technical Specifications

Casing Material : Cold rolled Steel body
Colors: yellow & grey . other colors to special order
Handset Material: Cycloy with stainless steel spiral cord
Keypad: Weatherproof Rubber Keypad
Temperature: Operating: -30°C to +65°C - Storing: -40°C to +75°C
Weather Resistance: IP66-IP67
Ring Tone: Shrill warble tone 90 dBA @ 1 meter typical
Hook switch: Electronic / magnetic
M.T.B.F.: in excess of 50,000 hours using
Weight: Up to 5 Kg depending on option
Dimensions: 240 x 334 x 109 mm
Packing: Carton 200 x 300 x 400 mm , 6Kg

Analog Specifications

Dialing : MF (Tone)
Power Supply: from telephone line
Lightning / Transients : Protective to ITU-T k.21 enhanced levels
Programming : can be programmed as an auto-dial phone

SIP / VoIP Specifications

Adaptor input : 100-240 VAC 55-60Hz , Output: 5V/1A
Port: WAN: 10/100Base - TRJ-45 for LAN, Auto MDIX - LAN: 10/100Base - TRJ-45 for PC, Auto MDIX
Power Consumption : Idle: 1.5W / Active : 1.8 W
Main Chip : Broadcom
Voice Feature: Support 2 lines SIP, SIP 2.0 (RFC32610)
Codec : .711A/u, G.7231 high/low, G.729, G.722, G.729
Echo Cancellation: Support G.168 and hand-free can support 96 ms Full Duplex: Supported
Support: SIP support, SIP Domain, SIP authentication (non basic, MD5) DNS name of server, peer to peer
SIP Support 2 servers, user can through each server to calling in and out
Network Features :
 - WAN/LAM: support Bridge Mode
 - Support PPPoE for xDSL
 - Support VLAN
 - Support Stun penetration
 - Support DHCP get IP on WAN port

GSM / 3G Specifications

Standard SIM card
- GSM : GSM 850/900/1800/1900 MHz
- 3G: WCDMA 850/1900/2100 MHz
Adapter Input : 7.4 V- 12 V DC
Power Consumption : Idle: 75mA / Active :160 mA

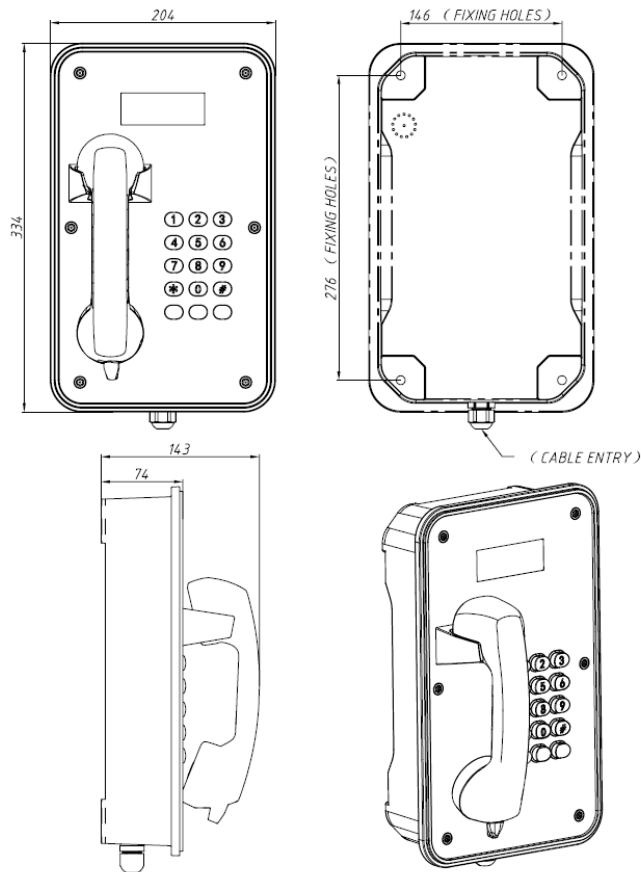

Ordering Information:

Part Number	Description
TK-105-FK-ANG	Analogue Telephone
TK-105-FK-SIP	SIP / VoIP Telephone
TK-105-FK-GSM	GSM / 3G Telephone
TK-105-FK-3G	3G Telephone

Please send your inquiries to: info@tashkoo.com

Information provided is subject to change without notice

Full Keypad, With Protection Door



- Vandal resistant handset and cord
- Weather proof protection IP66-IP67
- Full keypad with memory, 0-9 buttons can be programmed as speed dial button.
- "LR" button for last number redial
- "R" for flash recall
- "M" for muting
- Wall or top of pole mounting, simple installation
- Inductive coupler fitted as standard for hard of hearing
- Phone line powered (Analogue)
- External power supply or PoE (SIP-VoIP)
- RJ45 port for SIP phone
- CE compliant

TASHKOO offered weatherproof telephones are fully contained within a corrosion resistant cast aluminum weatherproof case with a door providing complete protection against dust and moisture ingress, resulting in a highly reliable product with a long MTBF.

The unique robust handset is manufactured from moulded Bulk Molding Compound and designed specifically to withstand arduous use in all environments, armoured cord to provide additional resistance to vandalism or heavy industrial use. These Weatherproof Telephones are designed for use by the railways, power stations, the armed services and heavy industry which require very reliable telephony under adverse conditions. Powdercoat finish available in Yellow or Grey, durable and resistant to discolouration yet easily cleaned. Installation is simple and quick via M20 cable glands on to fast-fit connectors which are accessed without the need for dismantling the telephone body.



Technical Specifications

Casing Material : Cold rolled Steel body
Colors: yellow & grey . other colors to special order
Handset Material: Cycloloy with stainless steel spiral cord
Keypad: Weatherproof Rubber Keypad
Temperature: Operating: -30°C to +65°C - Storing: -40°C to +75°C
Weather Resistance: IP66-IP67
Ringing Tone: Shrill warble tone 90 dBA @ 1 meter typical
Hook switch: Electronic / magnetic
M.T.B.F.: in excess of 50,000 hours using
Weight: Up to 6 Kg depending on option
Dimensions: 240 x 334 x 109 mm
Packing: Carton 200 x 300 x 400 mm , 7Kg

Analog Specifications

Dialing : MF (Tone)
Power Supply: from telephone line
Lightning / Transients : Protective to ITU-T k.21 enhanced levels
Programming : can be programmed as an auto-dial phone

SIP / VoIP Specifications

Adaptor input : 100-240 VAC 55-60Hz , Output: 5V/1A
Port: WAN: 10/100Base - TRJ-45 for LAN, Auto MDIX - LAN: 10/100Base - TRJ-45 for PC, Auto MDIX
Power Consumption : Idle: 1.5W / Active : 1.8 W
Main Chip : Broadcom
Voice Feature: Support 2 lines SIP, SIP 2.0 (RFC32610)
Codec: .711A/u, G.7231 high/low. G.729, G.722, G.729
Echo Cancellation: Support G.168 and hand-free can support 96 ms
Full Duplex: Supported
Support: SIP support, SIP Domain, SIP authentication (non basic, MD5)
 DNS name of server, peer to peer
 SIP Support 2 servers, user can through each server to calling in and out
Network Features :
 - WAN/LAM: support Bridge Mode
 - Support PPPoE for xDSL
 - Support VLAN
 - Support Stun penetration
 - Support DHCP get IP on WAN port

GSM / 3G Specifications

Standard SIM card
- GSM : GSM 850/900/1800/1900 MHz
- 3G: WCDMA 850/1900/2100 MHz
Adapter Input : 7.4 V- 12 V DC
Power Consumption : Idle: 75mA / Active :160 mA

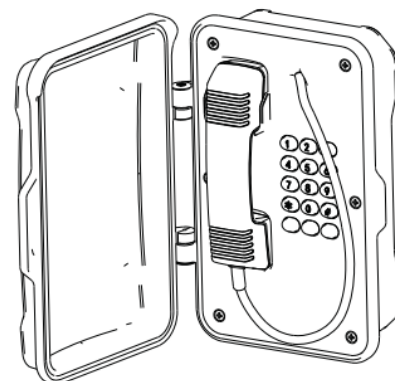
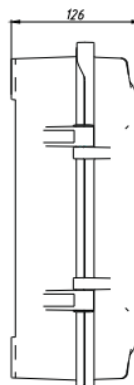
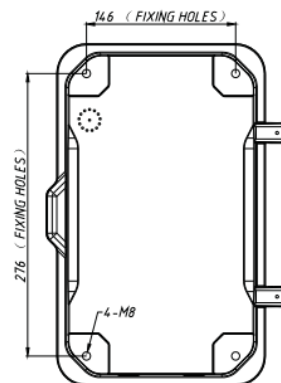
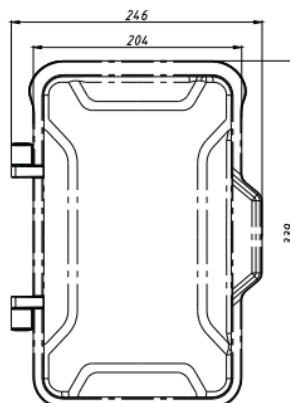

Ordering Information:

Part Number	Description
TK-101-FK-ANG	Analogue Telephone
TK-101-FK-SIP	SIP / VoIP Telephone
TK-101-FK-GSM	GSM Telephone
TK-101-FK-3G	3G Telephone

Please send your inquiries to: info@tashkoo.com

Information provided is subject to change without notice

Full Keypad, Without Protection Door



- Vandal resistant handset and cord
- Weather proof protection IP66-IP67
- Full keypad with memory, 0-9 buttons can be programmed as speed dial button.
- “LR” button for last number redial
- “R” for flash recall
- “M” for muting
- Wall or top of pole mounting, simple installation
- Inductive coupler fitted as standard for hard of hearing
- Phone line powered (Analogue)
- External power supply or PoE (SIP-VoIP)
- RJ45 port for SIP phone
- CE compliant

TASHKOO offered weatherproof telephones are fully contained within a corrosion resistant cast aluminum weatherproof case providing complete protection against dust and moisture ingress, resulting in a highly reliable product with a long MTBF.

The unique robust handset is manufactured from moulded Bulk Molding Compound and designed specifically to withstand arduous use in all environments, armoured cord to provide additional resistance to vandalism or heavy industrial use. These Weatherproof Telephones are designed for use by the railways, power stations, the armed services and heavy industry which require very reliable telephony under adverse conditions. Powdercoat finish available in Yellow or Grey, durable and resistant to discolouration yet easily cleaned. Installation is simple and quick via M20 cable glands on to fast-fit connectors which are accessed without the need for dismantling the telephone body.

Technical Specifications

Casing Material : Cold rolled Steel body
Colors: yellow & grey . other colors to special order
Handset Material: Cycology with stainless steel spiral cord
Keypad: Weatherproof Rubber Keypad
Temperature: Operating: -30°C to +65°C - Storing: -40°C to +75°C
Weather Resistance: IP66-IP67
Ringing Tone: Shrill warble tone 90 dBA @ 1 meter typical
Hook switch: Electronic / magnetic
M.T.B.F.: in excess of 50,000 hours using
Weight: Up to 5 Kg depending on option
Dimensions: 240 x 334 x 109 mm
Packing: Carton 200 x 300 x 400 mm , 6 Kg

Analog Specifications

Dialing : MF (Tone)
Power Supply: from telephone line
Lightning / Transients : Protective to ITU-T k.21 enhanced levels
Programming : can be programmed as an auto-dial phone

SIP / VoIP Specifications

Adaptor input : 100-240 VAC 55-60Hz , Output: 5V/1A
Port: WAN: 10/100Base - TRJ-45 for LAN, Auto MDIX - LAN: 10/100Base - TRJ-45 for PC, Auto MDIX
Power Consumption : Idle: 1.5W / Active : 1.8 W
Main Chip : Broadcom
Voice Feature: Support 2 lines SIP, SIP 2.0 (RFC32610)
Codec: .711A/u, G.7231 high/low, G.729, G.722, G.729
Echo Cancellation: Support G.168 and hand-free can support 96 ms
Full Duplex: Supported
Support: SIP support, SIP Domain, SIP authentication (non basic, MD5)
 DNS name of server, peer to peer
 SIP Support 2 servers, user can through each server to calling in and out
Network Features :
 - WAN/LAM: support Bridge Mode
 - Support PPPoE for xDSL
 - Support VLAN
 - Support Stun penetration
 - Support DHCP get IP on WAN port

GSM / 3G Specifications

Standard SIM card
 - **GSM :** GSM 850/900/1800/1900 MHz
 - **3G:** WCDMA 850/1900/2100 MHz
Adapter Input : 7.4 V- 12 V DC
Power Consumption : Idle: 75mA / Active :160 mA

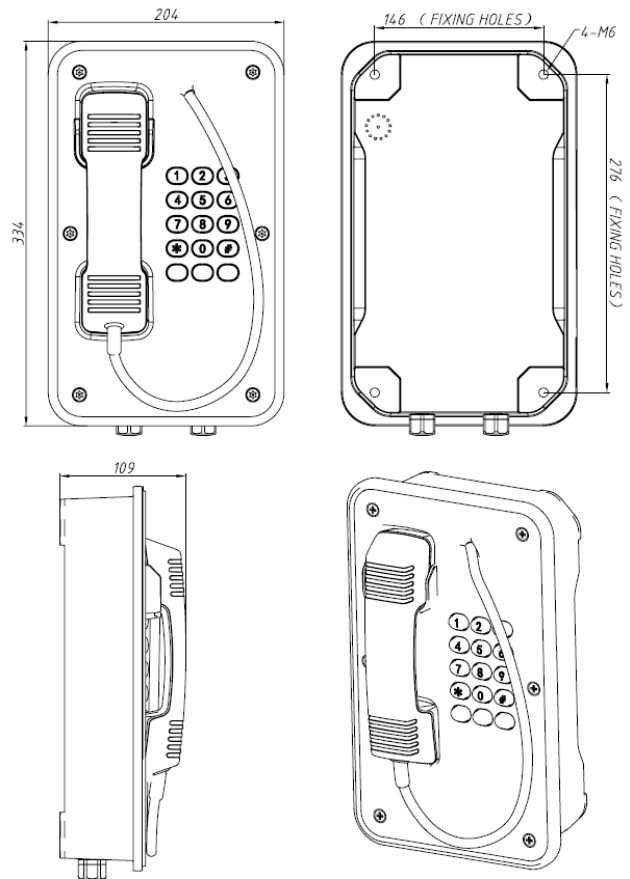

Ordering Information:

Part Number	Description
TK-103-FK-ANG	Analogue Telephone
TK-103-FK-SIP	SIP / VoIP Telephone
TK-103-FK-GSM	GSM / 3G Telephone
TK-103-FK-3G	3G Telephone

Information provided is subject to change without notice

Please send your inquiries to: info@tashkoo.com

Hot Line, With Protection Door



- Vandal resistant handset and cord
- Aluminum alloy die-casting body
- Weather proof protection IP66-IP67
- Programmable for auto-dial
- Wall or top of pole mounting, simple installation
- Inductive coupler fitted as standard for hard of hearing
- Phone line powered (Analogue)
- External power supply or PoE (SIP-VoIP)
- RJ45 port for SIP phone
- CE compliant

TASHKOO offered weatherproof telephones are fully contained within a corrosion resistant cast aluminum weatherproof case with a door providing complete protection against dust and moisture ingress, resulting in a highly reliable product with a long MTBF.

The unique robust handset is manufactured from moulded Bulk Molding Compound and designed specifically to withstand arduous use in all environments, armoured cord to provide additional resistance to vandalism or heavy industrial use. These Weatherproof Telephones are designed for use by the railways, power stations, the armed services and heavy industry which require very reliable telephony under adverse conditions. Powdercoat finish available in Yellow or Grey, durable and resistant to discolouration yet easily cleaned. Installation is simple and quick via M20 cable glands on to fast-fit connectors which are accessed without the need for dismantling the telephone body.

Technical Specifications

Casing Material : Cold rolled Steel body
Colors: yellow & grey . other colors to special order
Handset Material: Cylcoloy with stainless steel spiral cord
Keypad: No Keypad
Temperature: Operating: -30°C to +65°C - Storing: -40°C to +75°C
Weather Resistance: IP66-IP67
Ringng Tone: Shrill warble tone 90 dBA @ 1 meter typical
Hook switch: Electronic / magnetic
M.T.B.F.: in excess of 50,000 hours using
Weight: Up to 6 Kg depending on option
Dimensions: 240 x 334 x 109 mm
Packing: Carton 200 x 300 x 400 mm , 7 Kg

Analog Specifications

Dialing : MF (Tone)
Power Supply: from telephone line
Lightning / Transients : Protective to ITU-T k.21 enhanced levels
Programming : can be programmed as an auto-dial phone

SIP / VoIP Specifications

Adaptor input : 100-240 VAC 55-60Hz , Output: 5V/1A
Port: WAN: 10/100Base - TRJ-45 for LAN, Auto MDIX - LAN: 10/100Base - TRJ-45 for PC, Auto MDIX
Power Consumption : Idle: 1.5W / Active : 1.8 W
Main Chip : Broadcom
Voice Feature: Support 2 lines SIP, SIP 2.0 (RFC32610)
Codec: .711A/u, G.7231 high/low. G.729, G.722, G.729
Echo Cancellation: Support G.168 and hand-free can support 96 ms
Full Duplex: Supported
Support: SIP support, SIP Domain, SIP authentication (non basic, MD5)
 DNS name of server, peer to peer
 SIP Support 2 servers, user can through each server to calling in and out
Network Features :
 - WAN/LAM: support Bridge Mode
 - Support PPPoE for xDSL
 - Support VLAN
 - Support Stun penetration
 - Support DHCP get IP on WAN port

GSM / 3G Specifications

Standard SIM card
 - **GSM :** GSM 850/900/1800/1900 MHz
 - **3G:** WCDMA 850/1900/2100 MHz
Adapter Input : 7.4 V- 12 V DC
Power Consumption : Idle: 75mA / Active :160 mA

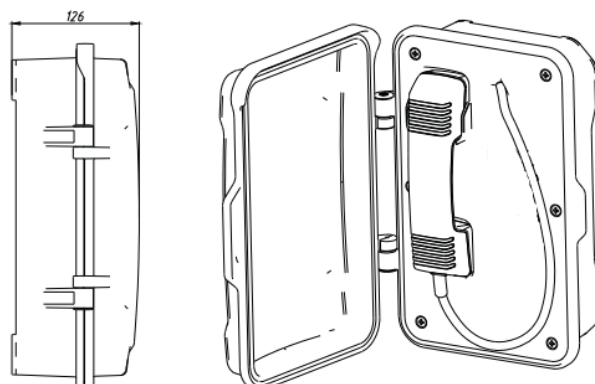
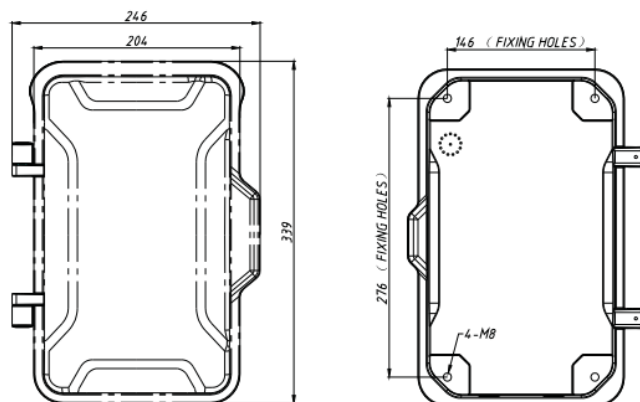

Ordering Information:

Part Number	Description
TK-101-CB-ANG	Analogue Telephone
TK-101-CB-SIP	SIP / VoIP Telephone
TK-101-CB-GSM	GSM Telephone
TK-101-CB-3G	3G Telephone

Please send your inquiries to: info@tashkoo.com

Information provided is subject to change without notice



Hot Line, Without Protection Door

- Vandal resistant handset and cord
- Aluminum alloy die-casting body
- Weather proof protection IP66-IP67
- Programmable for auto-dial
- Wall or top of pole mounting, simple installation
- Inductive coupler fitted as standard for hard of hearing
- Phone line powered (Analogue)
- External power supply or PoE (SIP-VoIP)
- RJ45 port for SIP phone
- CE compliant

TASHKOO offered weatherproof telephones are fully contained within a corrosion resistant cast aluminum weatherproof case providing complete protection against dust and moisture ingress, resulting in a highly reliable product with a long MTBF.

The unique robust handset is manufactured from moulded Bulk Molding Compound and designed specifically to withstand arduous use in all environments, armoured cord to provide additional resistance to vandalism or heavy industrial use. These Weatherproof Telephones are designed for use by the railways, power stations, the armed services and heavy industry which require very reliable telephony under adverse conditions. Powdercoat finish available in Yellow or Grey, durable and resistant to discolouration yet easily cleaned. Installation is simple and quick via M20 cable glands on to fast-fit connectors which are accessed without the need for dismantling the telephone body.

Technical Specifications

Casing Material : Cold rolled Steel body
Colors: yellow & grey . other colors to special order
Handset Material: Cylcoloy with stainless steel spiral cord
Keypad: No Keypad
Temperature: Operating: -30°C to +65°C - Storing: -40°C to +75°C
Weather Resistance: IP66-IP67
Ring Tone: Shrill warble tone 90 dBA @ 1 meter typical
Hook switch: Electronic / magnetic
M.T.B.F.: in excess of 50,000 hours using
Weight: Up to 5 Kg depending on option
Dimensions: 240 x 334 x 109 mm
Packing: Carton 200 x 300 x 400 mm , 6 Kg

Analog Specifications

Dialing : MF (Tone)
Power Supply: from telephone line
Lightning / Transients : Protective to ITU-T k.21 enhanced levels
Programming : can be programmed as an auto-dial phone

SIP / VoIP Specifications

Adaptor input : 100-240 VAC 55-60Hz , Output: 5V/1A
Port: WAN: 10/100Base - TRJ-45 for LAN, Auto MDIX - LAN: 10/100Base - TRJ-45 for PC, Auto MDIX
Power Consumption : Idle: 1.5W / Active : 1.8 W
Main Chip : Broadcom
Voice Feature: Support 2 lines SIP, SIP 2.0 (RFC32610)
Codec: .711A/u, G.7231 high/low. G.729, G.722, G.729
Echo Cancellation: Support G.168 and hand-free can support 96 ms
Full Duplex: Supported
Support: SIP support, SIP Domain, SIP authentication (non basic, MD5)
 DNS name of server, peer to peer
 SIP Support 2 servers, user can through each server to calling in and out
Network Features :
 - WAN/LAM: support Bridge Mode
 - Support PPPoE for xDSL
 - Support VLAN
 - Support Stun penetration
 - Support DHCP get IP on WAN port

GSM / 3G Specifications

Standard SIM card
- GSM : GSM 850/900/1800/1900 MHz
- 3G: WCDMA 850/1900/2100 MHz
Adapter Input : 7.4 V- 12 V DC
Power Consumption : Idle: 75mA / Active :160 mA

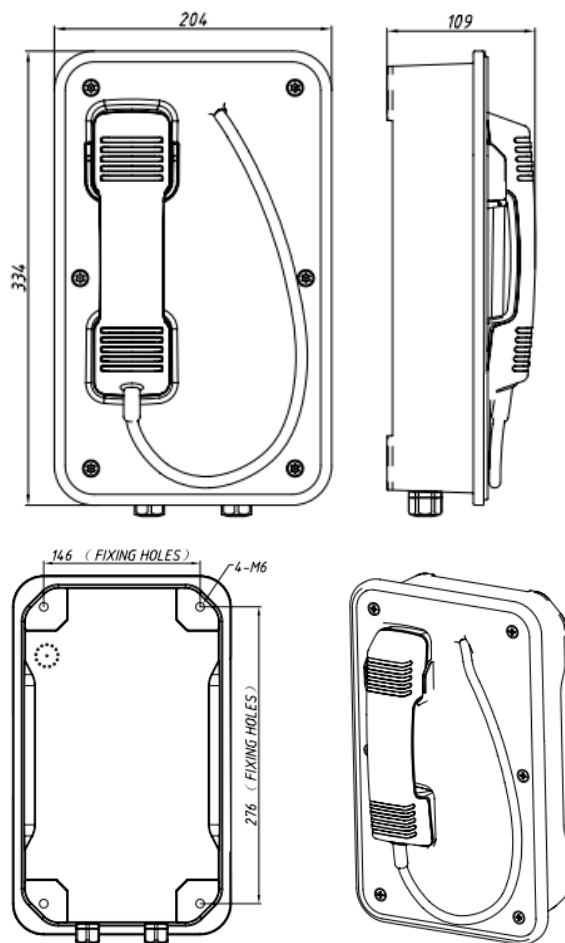

Ordering Information:

Part Number	Description
TK-103-CB-ANG	Analogue Telephone
TK-103-CB-SIP	SIP / VoIP Telephone
TK-103-CB-GSM	GSM Telephone
TK-103-CB-3G	3G Telephone

Information provided is subject to change without notice

Please send your inquiries to: info@tashkoo.com

Full Keypad, With Door , Horn and/or Beacon



- Vandal resistant handset and cord
- Weather proof protection IP66-IP67
- Full keypad with memory, 0-9 buttons can be programmed as speed dial button.
- "LR" button for last number redial
- "R" for flash recall
- "M" for muting
- Wall or top of pole mounting, simple installation
- Inductive coupler fitted as standard for hard of hearing
- Phone line powered (Analogue)
- External power supply or PoE (SIP-VoIP)
- RJ45 port for SIP phone
- CE compliant

TASHKOO offered weatherproof telephones are fully contained within a corrosion resistant cast aluminum weatherproof case with a door providing complete protection against dust and moisture ingress, resulting in a highly reliable product with a long MTBF.

The unique robust handset is manufactured from moulded Bulk Molding Compound and designed specifically to withstand arduous use in all environments, armoured cord to provide additional resistance to vandalism or heavy industrial use. These Weatherproof Telephones are designed for use by the railways, power stations, the armed services and heavy industry which require very reliable telephony under adverse conditions. Powdercoat finish available in Yellow or Grey, durable and resistant to discolouration yet easily cleaned. Installation is simple and quick via M20 cable glands on to fast-fit connectors which are accessed without the need for dismantling the telephone body.

Technical Specifications

Casing Material : Die cast aluminum, epoxy powder coated
Colors: yellow & grey . other colors to special order
Handset Material: Industrial BMC material with stainless steel spiral cord.
Keypad: Weather sealed tactile sillican rubber. Vandal resistance.
Temperature: Operating: -30°C to +65°C - Storing: -40°C to +75°C
Weather Resistance: IP66-IP67
Ring Tone: Shrill warble tone 90 dBA @ 1 meter typical
Hook switch: Electronic / magnetic
M.T.B.F.: in excess of 50,000 hours using
Weight: Up to 6 Kg depending on option
Dimensions: 240 x 334 x 109 mm
Packing: Carton 200 x 300 x 400 mm , 7Kg

Analog Specifications

Dialing : MF (Tone)
Power Supply: from telephone line
Lightning / Transients : Protective to ITU-T k.21 enhanced levels
Programming : can be programmed as an auto-dial phone

SIP / VoIP Specifications

Adaptor input : 100-240 VAC 55-60Hz , Output: 5V/1A
Port: WAN: 10/100Base - TRJ-45 for LAN, Auto MDIX - LAN: 10/100Base - TRJ-45 for PC, Auto MDIX
Power Consumption : Idle: 1.5W / Active : 1.8 W
Main Chip : Broadcom
Voice Feature: Support 2 lines SIP, SIP 2.0 (RFC32610)
Codec: .711A/u, G.7231 high/low. G.729, G.722, G.729
Echo Cancellation: Support G.168 and hand-free can support 96 ms
 Full Duplex: Supported
Support: SIP support, SIP Domain, SIP authentication (non basic, MD5)
 DNS name of server, peer to peer
 SIP Support 2 servers, user can through each server to calling in and out
Network Features :
 - WAN/LAM: support Bridge Mode
 - Support PPPoE for xDSL
 - Support VLAN
 - Support Stun penetration
 - Support DHCP get IP on WAN port

GSM / 3G Specifications

Standard SIM card
- GSM : GSM 850/900/1800/1900 MHz
- 3G: WCDMA 850/1900/2100 MHz
Adapter Input : 7.4 V- 12 V DC
Power Consumption : Idle: 75mA / Active :160 mA

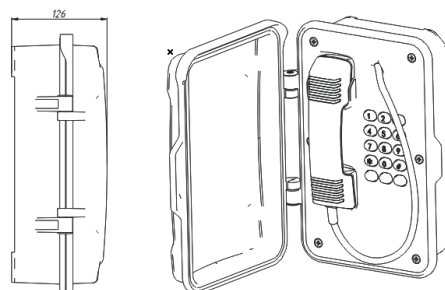
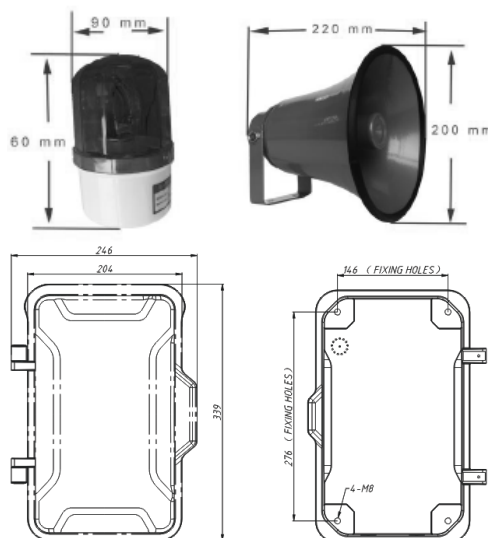

Ordering Information:

Part Number	Description
TK-101-FK-H-ANG	Analogue with Horn Telephone
TK-101-FK-H-SIP	SIP / VoIP with Horn Telephone
TK-101-FK-H-GSM	GSM with Horn Telephone
TK-101-FK-H-3G	3G with Horn Telephone
TK-101-FK-HB-ANG	Analogue with Horn & Beacon Telephone
TK-101-FK-HB-SIP	SIP / VoIP with Horn & Beacon Telephone
TK-101-FK-HB-GSM	GSM with Horn & Beacon Telephone
TK-101-FK-HB-3G	3G with Horn & Beacon Telephone

Information provided is subject to change without notice

Please send your inquiries to: info@tashkoo.com

Full Keypad, With Horn and/or Beacon



- Vandal resistant handset and cord
- Weather proof protection IP66-IP67
- Full keypad with memory, 0-9 buttons can be programmed as speed dial button.
- "LR" button for last number redial
- "R" for flash recall
- "M" for muting
- Wall or top of pole mounting, simple installation
- Inductive coupler fitted as standard for hard of hearing
- Phone line powered (Analogue)
- External power supply or PoE (SIP-VoIP)
- RJ45 port for SIP phone
- CE compliant

TASHKOO offered weatherproof telephones are fully contained within a corrosion resistant cast aluminum weatherproof case with a door providing complete protection against dust and moisture ingress, resulting in a highly reliable product with a long MTBF.

The unique robust handset is manufactured from moulded Bulk Molding Compound and designed specifically to withstand arduous use in all environments, armoured cord to provide additional resistance to vandalism or heavy industrial use. These Weatherproof Telephones are designed for use by the railways, power stations, the armed services and heavy industry which require very reliable telephony under adverse conditions. Powdercoat finish available in Yellow or Grey, durable and resistant to discolouration yet easily cleaned. Installation is simple and quick via M20 cable glands on to fast-fit connectors which are accessed without the need for dismantling the telephone body.

Technical Specifications

Casing Material : Die cast aluminum, epoxy powder coated
Colors: yellow & grey . other colors to special order
Handset Material: Industrial BMC material with stainless steel spiral cord.
Keypad: Weather sealed tactile silicone rubber. Vandal resistance.
Temperature: Operating: -30°C to +65°C - Storing: -40°C to +75°C
Weather Resistance: IP66-IP67
Ring Tone: Shrill warble tone 90 dBA @ 1 meter typical
Hook switch: Electronic / magnetic
M.T.B.F.: in excess of 50,000 hours using
Weight: Up to 6 Kg depending on option
Dimensions: 240 x 334 x 109 mm
Packing: Carton 200 x 300 x 400 mm , 7Kg

Analog Specifications

Dialing : MF (Tone)
Power Supply: from telephone line
Lightning / Transients : Protective to ITU-T k.21 enhanced levels
Programming : can be programmed as an auto-dial phone

SIP / VoIP Specifications

Adaptor input : 100-240 VAC 55-60Hz , Output: 5V/1A
Port: WAN: 10/100Base - TRJ-45 for LAN, Auto MDIX - LAN: 10/100Base - TRJ-45 for PC, Auto MDIX
Power Consumption : Idle: 1.5W / Active : 1.8 W
Main Chip : Broadcom
Voice Feature: Support 2 lines SIP, SIP 2.0 (RFC32610)
Codec: .711A/u, G.7231 high/low. G.729, G.722, G.729
Echo Cancellation: Support G.168 and hand-free can support 96 ms
Full Duplex: Supported
Support: SIP support, SIP Domain, SIP authentication (non basic, MD5)
 DNS name of server, peer to peer
 SIP Support 2 servers, user can through each server to calling in and out
Network Features :
 - WAN/LAM: support Bridge Mode
 - Support PPPoE for xDSL
 - Support VLAN
 - Support Stun penetration
 - Support DHCP get IP on WAN port

GSM / 3G Specifications

Standard SIM card
 - **GSM :** GSM 850/900/1800/1900 MHz
 - **3G:** WCDMA 850/1900/2100 MHz
Adapter Input : 7.4 V- 12 V DC
Power Consumption : Idle: 75mA / Active :160 mA

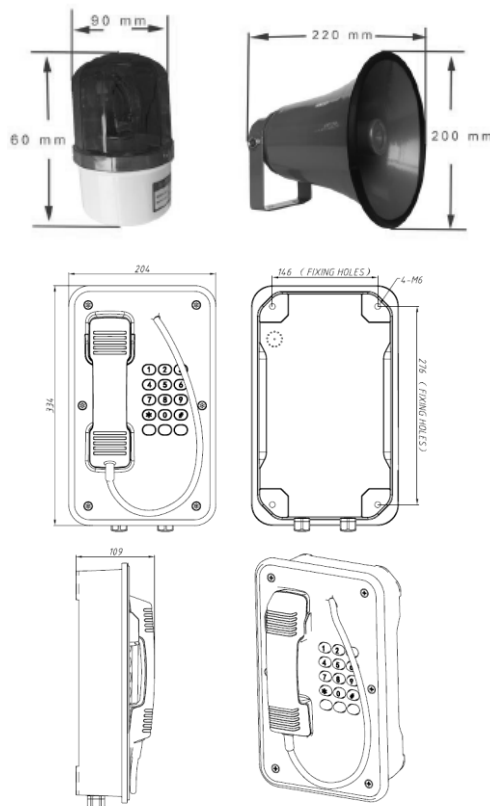

Ordering Information:

Part Number	Description
TK-103-FK-H-ANG	Analogue with Horn Telephone
TK-103-FK-H -SIP	SIP / VoIP with Horn Telephone
TK-103-FK-H -GSM	GSM with Horn Telephone
TK-103-FK-H -3G	3G with Horn Telephone
TK-103-FK-HB-ANG	Analogue with Horn & Beacon Telephone
TK-103-FK-HB -SIP	SIP / VoIP with Horn & Beacon Telephone
TK-103-FK-HB -GSM	GSM with Horn & Beacon Telephone
TK-103-FK-HB -3G	3G with Horn & Beacon Telephone

Please send your inquiries to: info@tashkoo.com

Information provided is subject to change without notice

Spee Dial, With Protection Door



- Aluminum alloy die-casting body
- Weather proof protection IP66-IP67
- Hands free operation
- One or Two button for emergency call
- Wall or top of pole mounting, simple installation
- Inductive coupler fitted as standard for hard of hearing
- Phone line powered (Analogue)
- External power supply or PoE (SIP-VoIP)
- RJ45 port for SIP phone
- CE compliant

TASHKOO offered weatherproof telephones are fully contained within a corrosion resistant cast aluminum weatherproof case with a door providing complete protection against dust and moisture ingress, resulting in a highly reliable product with a long MTBF.

The unique robust handset is manufactured from moulded Bulk Molding Compound and designed specifically to withstand arduous use in all environments, armoured cord to provide additional resistance to vandalism or heavy industrial use. These Weatherproof Telephones are designed for use by the railways, power stations, the armed services and heavy industry which require very reliable telephony under adverse conditions. Powdercoat finish available in Yellow or Grey, durable and resistant to discolouration yet easily cleaned. Installation is simple and quick via M20 cable glands on to fast-fit connectors which are accessed without the need for dismantling the telephone body.

Technical Specifications

Casing Material : Cold rolled Steel body
Colors: yellow & grey . other colors to special order
Handset Material: No Handset
Keypad: No Keypad
Temperature: Operating: -30°C to +65°C - Storing: -40°C to +75°C
Weather Resistance: IP66-IP67
Ring Tone: Shrill warble tone 90 dBA @ 1 meter typical
Hook switch: No Hook switch
M.T.B.F.: in excess of 50,000 hours using
Weight: Up to 6 Kg depending on option
Dimensions: 240 x 334 x 109 mm
Packing: Carton 200 x 300 x 400 mm , 7 Kg

Analog Specifications

Dialing : MF (Tone)
Power Supply: from telephone line
Lightning / Transients : Protective to ITU-T k.21 enhanced levels
Programming : can be programmed as an auto-dial phone

SIP / VoIP Specifications

Adaptor input : 100-240 VAC 55-60Hz , Output: 5V/1A
Port: WAN: 10/100Base - TRJ-45 for LAN, Auto MDIX - LAN: 10/100Base - TRJ-45 for PC, Auto MDIX
Power Consumption : Idle: 1.5W / Active : 1.8 W
Main Chip : Broadcom
Voice Feature: Support 2 lines SIP, SIP 2.0 (RFC32610)
Codec: .711A/u, G.7231 high/low, G.729, G.722, G.729
Echo Cancellation: Support G.168 and hand-free can support 96 ms
Full Duplex: Supported
Support: SIP support, SIP Domain, SIP authentication (non basic, MD5)
 DNS name of server, peer to peer
 SIP Support 2 servers, user can through each server to calling in and out
Network Features :
 - WAN/LAM: support Bridge Mode
 - Support PPPoE for xDSL
 - Support VLAN
 - Support Stun penetration
 - Support DHCP get IP on WAN port

GSM / 3G Specifications

Standard SIM card
 - **GSM :** GSM 850/900/1800/1900 MHz
 - **3G:** WCDMA 850/1900/2100 MHz
Adapter Input : 7.4 V- 12 V DC
Power Consumption : Idle: 75mA / Active :160 mA

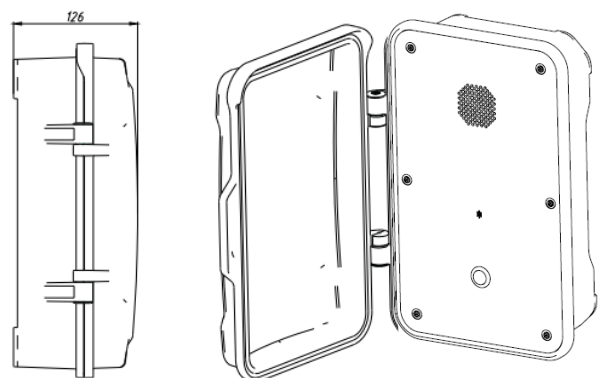
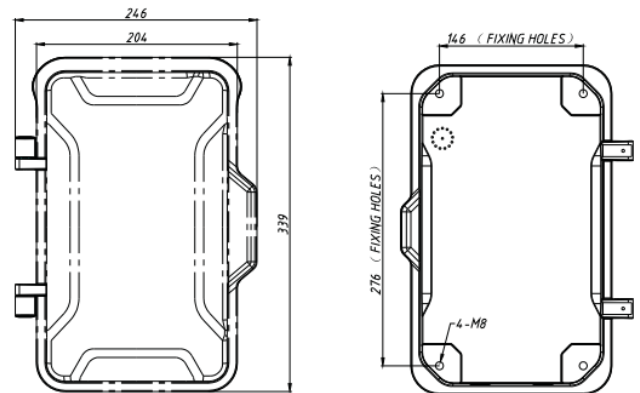

Ordering Information:

Part Number	Description
TK-102-1B-ANG	Analogue Telephone, 1 buttons
TK-102-1B-SIP	SIP / VoIP Telephone, 1 buttons
TK-102-1B-GSM	GSM Telephone, 1 buttons
TK-102-1B-3G	3G Telephone, 1 buttons
TK-102-2B-ANG	Analogue Telephone, 2 buttons
TK-102-2B-SIP	SIP / VoIP Telephone, 2 buttons
TK-102-2B-GSM	GSM Telephone, 2 buttons
TK-102-2B-3G	3G Telephone, 2 buttons

Information provided is subject to change without notice

Please send your inquiries to: info@tashkoo.com

Spee Dial, Without Protection Door



- Aluminum alloy die-casting body
- Weather proof protection IP66-IP67
- Hands free operation
- One or Two button for emergency call
- Wall or top of pole mounting, simple installation
- Inductive coupler fitted as standard for hard of hearing
- Phone line powered (Analogue)
- External power supply or PoE (SIP-VoIP)
- RJ45 port for SIP phone
- CE compliant

TASHKOO offered weatherproof telephones are fully contained within a corrosion resistant cast aluminum weatherproof case providing complete protection against dust and moisture ingress, resulting in a highly reliable product with a long MTBF.

The unique robust handset is manufactured from moulded Bulk Molding Compound and designed specifically to withstand arduous use in all environments, armoured cord to provide additional resistance to vandalism or heavy industrial use. These Weatherproof Telephones are designed for use by the railways, power stations, the armed services and heavy industry which require very reliable telephony under adverse conditions. Powdercoat finish available in Yellow or Grey, durable and resistant to discolouration yet easily cleaned. Installation is simple and quick via M20 cable glands on to fast-fit connectors which are accessed without the need for dismantling the telephone body.

Technical Specifications

Casing Material : Cold rolled Steel body
Colors: yellow & grey . other colors to special order
Handset Material: No Handset
Push button: Vandal resistant stainless steel button
Temperature: Operating: -30°C to +65°C - Storing: -40°C to +75°C
Weather Resistance: IP66-IP67
Ringing Tone: Shriill warble tone 90 dBA @ 1 meter typical
Hook switch: No Hook switch
M.T.B.F.: in excess of 50,000 hours using
Weight: Up to 5 Kg depending on option
Dimensions: 240 x 334 x 109 mm
Packing: Carton 200 x 300 x 400 mm , 6 Kg

Analog Specifications

Dialing : MF (Tone)
Power Supply: from telephone line
Lightning / Transients : Protective to ITU-T k.21 enhanced levels
Programming : can be programmed as an auto-dial phone

SIP / VoIP Specifications

Adaptor input : 100-240 VAC 55-60Hz , Output: 5V/1A
Port: WAN: 10/100Base - TRJ-45 for LAN, Auto MDIX - LAN: 10/100Base - TRJ-45 for PC, Auto MDIX
Power Consumption : Idle: 1.5W / Active : 1.8 W
Main Chip : Broadcom
Voice Feature: Support 2 lines SIP, SIP 2.0 (RFC32610)
Codec: .711A/u, G.7231 high/low. G.729, G.722, G.729
Echo Cancellation: Support G.168 and hand-free can support 96 ms
 Full Duplex: Supported
Support: SIP support, SIP Domain, SIP authentication (non basic, MD5)
 DNS name of server, peer to peer
 SIP Support 2 servers, user can through each server to calling in and out
Network Features :
 - WAN/LAM: support Bridge Mode
 - Support PPPoE for xDSL
 - Support VLAN
 - Support Stun penetration
 - Support DHCP get IP on WAN port

GSM / 3G Specifications

Standard SIM card
- GSM : GSM 850/900/1800/1900 MHz
- 3G: WCDMA 850/1900/2100 MHz
Adapter Input : 7.4 V- 12 V DC
Power Consumption : Idle: 75mA / Active :160 mA

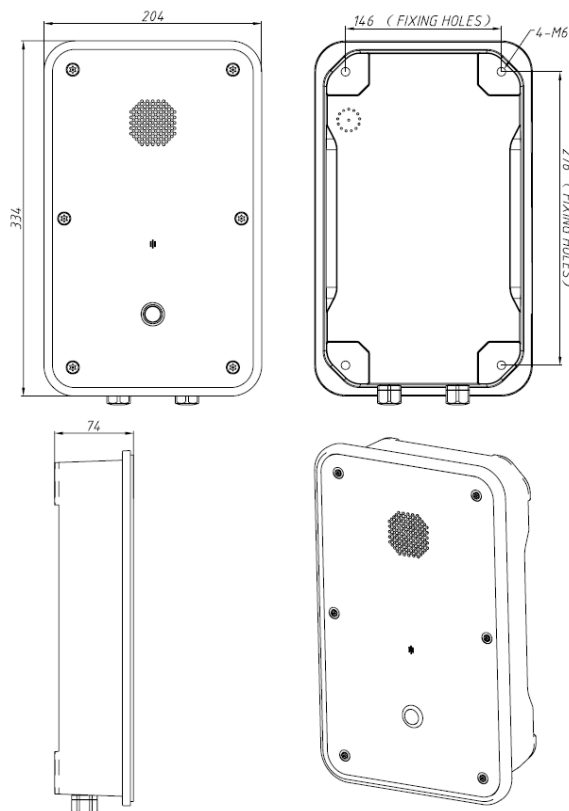

Ordering Information:

Part Number	Description
TK-104-1B-ANG	Analogue Telephone, 1 buttons
TK-104-1B-SIP	SIP / VoIP Telephone, 1 buttons
TK-104-1B-GSM	GSM Telephone, 1 buttons
TK-104-1B-3G	3G Telephone, 1 buttons
TK-104-2B-ANG	Analogue Telephone, 2 buttons
TK-104-2B-SIP	SIP / VoIP Telephone, 2 buttons
TK-104-2B-GSM	GSM Telephone, 2 buttons
TK-104-2B-3G	3G Telephone, 2 buttons

Information provided is subject to change without notice

Please send your inquiries to: info@tashkoo.com

Full Keypad Wall Mounting Telephone



- Vandal resistant handset and armored cord
- Robust housing, constructed of cold rolled steel with powder coat
- Full Rugged & durable keypad, easy to operate
- Weather proof protection IP65
- Programmable for auto-dial
- One or Two button for emergency call
- Wall or top of pole mounting, simple installation
- Inductive coupler fitted as standard for hard of hearing
- Phone line powered (Analogue)
- External power supply or PoE (SIP-VoIP)
- RJ45 port for SIP phone
- CE , FCC compliant

TASHKOO offered weatherproof telephones are designed to meet the needs of client who experience loss through vandalism. Ideal for parking lots, prisons, railway/metro platforms, hospitals, police stations, ATM machines, stadiums, outside building etc.

Housed in cold rolled steel box and manufactured to a high standard, these telephones offer increased resistance to vandalism, and ensure that the primary function of communications is maintained at all times. Extremely easy to install. The cable entrance is on the back of the phone to prevent from artificial damage, while the keypad is weather and vandal resistant.



Technical Specifications

- Casing Material :** Cold rolled Steel body
- Colors:** yellow , red & grey . other colors to special order
- Handset Material:** ABS material with stainless steel spiral cord
- Keypad:** Weather sealed tactile digital keypad.Chrome key and frame made of zinc alloy. Vandal resistance
- Temperature:** Operating: -30°C to +65°C - Storing: -40°C to +75°C
- Weather Resistance:** IP65
- Ringing Tone:** Shrill warble tone 80 dBA @ 1 meter typical
- Hook switch:** Electronic / magnetic with no visible moving parts
- M.T.B.F.:** in excess of 40,000 hours using
- Dimensions & Weight (Type 1):** 253 x 143 x 151 mm , 2.7 Kg
- Dimensions & Weight (Type 2):** 247 x 130 x 132 mm , 2.7 Kg
- Packing (Type 1):** Carton 340 x 235 x 165 mm , 3.5 Kg
- Packing (Type 2):** Carton 340 x 235 x 165 mm , 3.5 Kg

Analog Specifications

- Dialing :** MF (Tone)
- Power Supply:** from telephone line
- Lightning / Transients :** Protective to ITU-T k.21 enhanced levels
- Programming :** can be programmed as an auto-dial phone

SIP / VoIP Specifications

- Adaptor input :** 100-240 VAC 55-60Hz , Output: 5V/1A
- Port:** WAN: 10/100Base - TRJ-45 for LAN, Auto MDIX - LAN: 10/100Base - TRJ-45 for PC, Auto MDIX
- Power Consumption :** Idle: 1.5W / Active : 1.8 W
- Main Chip :** Broadcom
- Voice Feature:** Support 2 lines SIP, SIP 2.0 (RFC32610)
- Codec:** .711A/u, G.7231 high/low. G.729, G.722, G.729
- Echo Cancellation:** Support G.168 and hand-free can support 96 ms
- Full Duplex:** Supported
- Support:** SIP support, SIP Domain, SIP authentication (non basic, MD5) DNS name of server, peer to peer
- SIP Support 2 servers,** user can through each server to calling in and out

Network Features :

- WAN/LAM: support Bridge Mode
- Support PPPoE for xDSL
- Support VLAN
- Support Stun penetration
- Support DHCP get IP on WAN port

GSM / 3G Specifications

- Standard SIM card
- **GSM :** GSM 850/900/1800/1900 MHz
- **3G:** WCDMA 850/1900/2100 MHz
- Adapter Input :** 7.4 V- 12 V DC
- Power Consumption :** Idle: 75mA / Active :160 mA

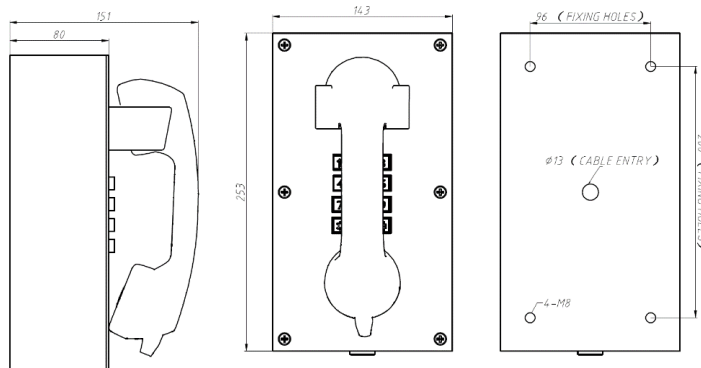

Type 1

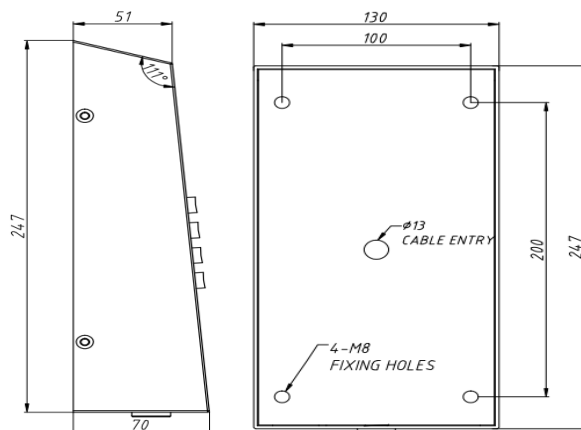

Type 2

Ordering Information:

Part Number	Description
TK-203-FK-ANG	Analogue Type 1, Telephone
TK-203-FK -SIP	SIP / VoIP Type 1, Telephone
TK-203-FK -GSM	GSM Type 1, Telephone
TK-203-FK -3G	3G Type 1, Telephone
TK-201-FK -ANG	Analogue Type 2, Telephone
TK-201-FK -SIP	SIP / VoIP Type 2, Telephone
TK-201-FK -GSM	GSM Type 2, Telephone
TK-201-FK -3G	3G Type 2, Telephone

Information provided is subject to change without notice

Please send your inquiries to: info@tashkoo.com

Full Keypad Flush Mounting Telephone



- Vandal resistant handset and armored cord
- Robust housing, constructed of cold rolled steel with powder coat
- Full Rugged & durable keypad, easy to operate
- Weather proof protection IP65
- Programmable for auto-dial
- One or Two button for emergency call
- Flush mounting, simple installation
- Inductive coupler fitted as standard for hard of hearing
- Phone line powered (Analogue)
- External power supply or PoE (SIP-VoIP)
- RJ45 port for SIP phone
- CE , FCC compliant

TASHKOO offered weatherproof telephones are designed to meet the needs of client who experience loss through vandalism. Ideal for parking lots, prisons, railway/metro platforms, hospitals, police stations, ATM machines, stadiums, outside building etc.

Housed in cold rolled steel box and manufactured to a high standard, these telephones offer increased resistance to vandalism, and ensure that the primary function of communications is maintained at all times. Extremely easy to install. The cable entrance is on the back of the phone to prevent from artificial damage, while the keypad is weather and vandal resistant.

Technical Specifications

Casing Material : Cold rolled Steel body
Colors: yellow , red & grey . other colors to special order
Handset Material: ABS material with stainless steel spiral cord
Keypad: Weather sealed tactile digital keypad.Chrome key and frame made of zinc alloy. Vandal resistance
Temperature: Operating: -30°C to +65°C - Storing: -40°C to +75°C
Weather Resistance: IP65
Ringing Tone: Shrill warble tone 80 dBA @ 1 meter typical
Hook switch: Electronic / magnetic with no visible moving parts
M.T.B.F.: in excess of 40,000 hours using
Dimensions & Weight : 280 x 190 x 124 mm, 2.7 Kg
Packing: Carton 340 x 235 x 165 mm , 3.5 Kg

Analog Specifications

Dialing : MF (Tone)
Power Supply: from telephone line
Lightning / Transients : Protective to ITU-T k.21 enhanced levels
Programming : can be programmed as an auto-dial phone

SIP / VoIP Specifications

Adaptor input : 100-240 VAC 55-60Hz , Output: 5V/1A
Port: WAN: 10/100Base - TRJ-45 for LAN, Auto MDIX - LAN: 10/100Base - TRJ-45 for PC, Auto MDIX
Power Consumption : Idle: 1.5W / Active : 1.8 W
Main Chip : Broadcom
Voice Feature: Support 2 lines SIP, SIP 2.0 (RFC32610)
Codec: .711A/u, G.7231 high/low, G.729, G.722, G.729
Echo Cancellation: Support G.168 and hand-free can support 96 ms
Full Duplex: Supported
Support: SIP support, SIP Domain, SIP authentication (non basic, MD5) DNS name of server, peer to peer
 SIP Support 2 servers, user can through each server to calling in and out
Network Features :
 - WAN/LAM: support Bridge Mode
 - Support PPPoE for xDSL
 - Support VLAN
 - Support Stun penetration
 - Support DHCP get IP on WAN port

GSM / 3G Specifications

Standard SIM card
- GSM : GSM 850/900/1800/1900 MHz
- 3G: WCDMA 850/1900/2100 MHz
Adapter Input : 7.4 V- 12 V DC
Power Consumption : Idle: 75mA / Active :160 mA

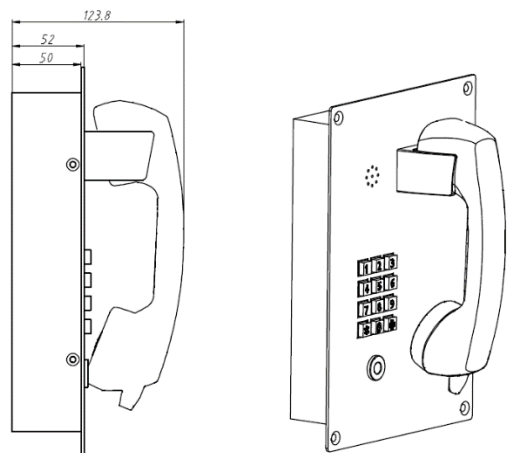
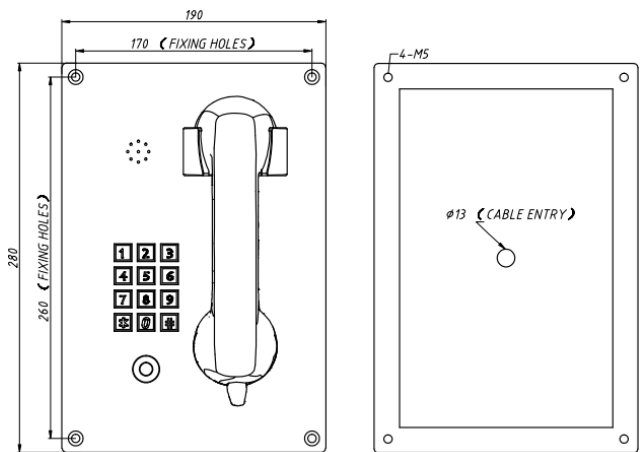

Ordering Information:

Part Number	Description
TK-208-FK-ANG	Analogue Flush Mounting, Telephone
TK-208-FK -SIP	SIP / VoIP Flush Mounting, Telephone
TK-208-FK -GSM	GSM Flush Mounting, Telephone
TK-208-FK -3G	3G Flush Mounting, Telephone

Please send your inquiries to: info@tashkoo.com

Information provided is subject to change without notice

Hot Line Wall Mounting Telephone



- Vandal resistant handset and armored cord
- Robust housing, constructed of stainless steel
- Weather proof protection IP65
- Programmable for auto-dial
- One or Two button for emergency call
- Wall mounting, simple installation
- Inductive coupler fitted as standard for hard of hearing
- Phone line powered (Analogue)
- External power supply or PoE (SIP-VoIP)
- RJ45 port for SIP phone
- CE , FCC compliant

TASHKOO offered weatherproof telephones are designed to meet the needs of client who experience loss through vandalism. Ideal for parking lots, prisons, railway/metro platforms, hospitals, police stations, ATM machines, stadiums, outside building etc.

Housed in cold rolled steel box and manufactured to a high standard, these telephones offer increased resistance to vandalism, and ensure that the primary function of communications is maintained at all times. Extremely easy to install. The cable entrance is on the back of the phone to prevent from artificial damage, while the keypad is weather and vandal resistant.

Technical Specifications

Casing Material : Cold rolled Steel body
Colors: yellow , red & grey . other colors to special order
Handset Material: ABS material with stainless steel spiral cord
Keypad: No Keypad
Temperature: Operating: -30°C to +65°C - Storing: -40°C to +75°C
Weather Resistance: IP65
Ring Tone: Shrill warble tone 80 dBA @ 1 meter typical
Hook switch: Electronic / magnetic with no visible moving parts
M.T.B.F.: in excess of 40,000 hours using
Dimensions & Weight : 240 x 100 x 106 mm, 2.7 Kg
Packing: Carton 340 x 235 x 165 mm , 3.5 Kg

Analog Specifications

Dialing : MF (Tone)
Power Supply: from telephone line
Lightning / Transients : Protective to ITU-T k.21 enhanced levels
Programming : can be programmed as an auto-dial phone

SIP / VoIP Specifications

Adaptor input : 100-240 VAC 55-60Hz , Output: 5V/1A
Port: WAN: 10/100Base - TRJ-45 for LAN, Auto MDIX - LAN:
 10/100Base - TRJ-45 for PC, Auto MDIX
Power Consumption : Idle: 1.5W / Active : 1.8 W
Main Chip : Broadcom
Voice Feature: Support 2 lines SIP, SIP 2.0 (RFC32610)
Codec: .711A/u, G.7231 high/low, G.729, G.722, G.729
Echo Cancellation: Support G.168 and hand-free can support 96 ms
 Full Duplex: Supported
Support: SIP support, SIP Domain, SIP authentication (non basic, MD5) DNS name of server, peer to peer
 SIP Support 2 servers, user can through each server to calling in and out
Network Features :
 - WAN/LAM: support Bridge Mode
 - Support PPPoE for xDSL
 - Support VLAN
 - Support Stun penetration
 - Support DHCP get IP on WAN port

GSM / 3G Specifications

Standard SIM card
 - **GSM :** GSM 850/900/1800/1900 MHz
 - **3G:** WCDMA 850/1900/2100 MHz
Adapter Input : 7.4 V- 12 V DC
Power Consumption : Idle: 75mA / Active :160 mA

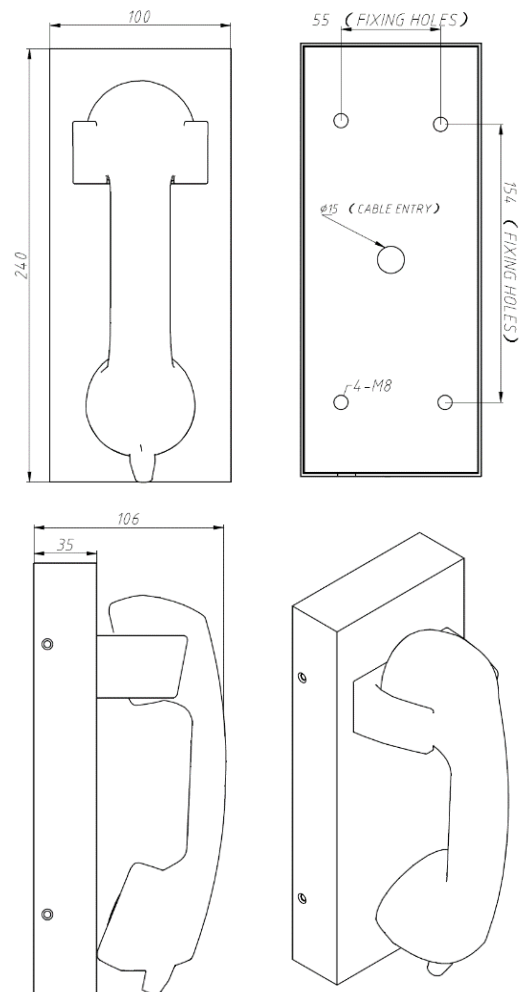

Ordering Information:

Part Number	Description
TK-202-CB-ANG	Analogue Hotline Wall Mounting Telephone
TK-202-CB -SIP	SIP / VoIP Hotline Wall Mounting Telephone
TK-202-CB -GSM	GSM Hotline Wall Mounting Telephone
TK-202-CB -3G	3G Hotline Wall Mounting Telephone

Information provided is subject to change without notice

Please send your inquiries to: info@tashkoo.com

Hot Line Flush Mounting Telephone



- Vandal resistant handset and armored cord
- Robust housing, constructed of stainless steel
- Weather proof protection IP65
- Programmable for auto-dial
- One or Two button for emergency call
- Wall mounting, simple installation
- Inductive coupler fitted as standard for hard of hearing
- Phone line powered (Analogue)
- External power supply or PoE (SIP-VoIP)
- RJ45 port for SIP phone
- CE , FCC compliant

TASHKOO offered weatherproof telephones are designed to meet the needs of client who experience loss through vandalism. Ideal for parking lots, prisons, railway/metro platforms, hospitals, police stations, ATM machines, stadiums, outside building etc.

Housed in cold rolled steel box and manufactured to a high standard, these telephones offer increased resistance to vandalism, and ensure that the primary function of communications is maintained at all times. Extremely easy to install. The cable entrance is on the back of the phone to prevent from artificial damage, while the keypad is weather and vandal resistant.

Technical Specifications

Casing Material : Cold rolled Steel body
Colors: yellow , red & grey . other colors to special order
Handset Material: ABS material with stainless steel spiral cord
Keypad: No Keypad
Temperature: Operating: -30°C to +65°C - Storing: -40°C to +75°C
Weather Resistance: IP65
Ring Tone: Shrill warble tone 80 dBA @ 1 meter typical
Hook switch: Electronic / magnetic with no visible moving parts
M.T.B.F.: in excess of 40,000 hours using
Dimensions & Weight : 240 x 100 x 106 mm, 2.7 Kg
Packing: Carton 340 x 235 x 165 mm , 3.5 Kg

Analog Specifications

Dialing : MF (Tone)
Power Supply: from telephone line
Lightning / Transients : Protective to ITU-T k.21 enhanced levels
Programming : can be programmed as an auto-dial phone

SIP / VoIP Specifications

Adaptor input : 100-240 VAC 55-60Hz , Output: 5V/1A
Port: WAN: 10/100Base - TRJ-45 for LAN, Auto MDIX - LAN:
 10/100Base - TRJ-45 for PC, Auto MDIX
Power Consumption : Idle: 1.5W / Active : 1.8 W
Main Chip : Broadcom
Voice Feature: Support 2 lines SIP, SIP 2.0 (RFC32610)
Codec: .711A/u, G.7231 high/low. G.729, G.722, G.729
Echo Cancellation: Support G.168 and hand-free can support 96 ms
 Full Duplex: Supported
Support: SIP support, SIP Domain, SIP authentication (non basic,
 MD5) DNS name of server, peer to peer
 SIP Support 2 servers, user can through each server to calling in and
 out
Network Features :
 - WAN/LAM: support Bridge Mode
 - Support PPPoE for xDSL
 - Support VLAN
 - Support Stun penetration
 - Support DHCP get IP on WAN port

GSM / 3G Specifications

Standard SIM card
 - **GSM :** GSM 850/900/1800/1900 MHz
 - **3G:** WCDMA 850/1900/2100 MHz
Adapter Input : 7.4 V- 12 V DC
Power Consumption : Idle: 75mA / Active :160 mA

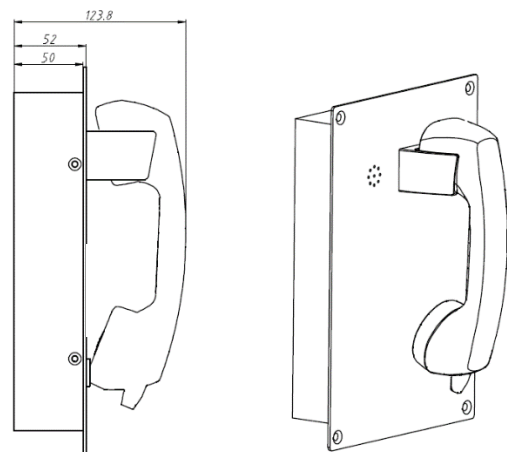
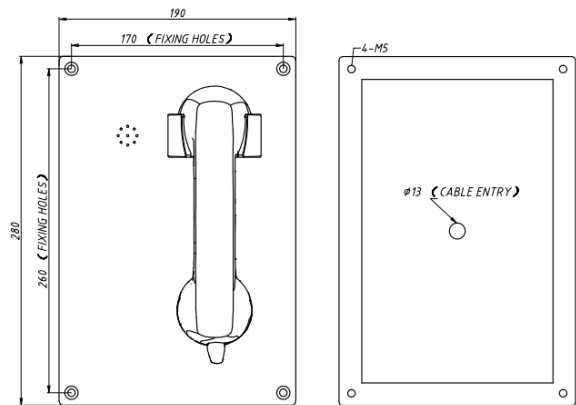

Ordering Information:

Part Number	Description
TK-208-CB-ANG	Analogue Hotline Flush Mounting Telephone
TK-208-CB -SIP	SIP / VoIP Hotline Flush Mounting
TK-208-CB -GSM	GSM Hotline Flush Mounting Telephone
TK-208-CB -3G	3G Hotline Flush Mounting Telephone

Please send your inquiries to: info@tashkoo.com

Information provided is subject to change without notice

Full Keypad Wall Mounting Telephone



- Vandal resistant handset and armored cord
- Robust housing, constructed of cold rolled steel with powder coated
- Weather proof protection IP65
- Full Rugged & durable keypad, easy to operate
- Programmable for auto-dial
- Wall mounting, simple installation
- Inductive coupler fitted as standard for hard of hearing
- Phone line powered (Analogue)
- External power supply or PoE (SIP-VoIP)
- RJ45 port for SIP phone
- CE , FCC compliant

TASHKOO offered weatherproof telephones are designed to meet the needs of client who experience loss through vandalism. Ideal for parking lots, prisons, railway/metro platforms, hospitals, police stations, ATM machines, stadiums, outside building etc.

Housed in cold rolled steel box and manufactured to a high standard, these telephones offer increased resistance to vandalism, and ensure that the primary function of communications is maintained at all times. Extremely easy to install. The cable entrance is on the back of the phone to prevent from artificial damage, while the keypad is weather and vandal resistant.



Technical Specifications

Casing Material : Cold rolled Steel body
Colors: yellow , red & grey . other colors to special order
Handset Material: ABS material with stainless steel spiral cord
Keypad: Weather sealed tactile digital keypad.Chrome key and frame made of zinc alloy.Vandal resistance.
Temperature: Operating: -30°C to +65°C - Storing: -40°C to +75°C
Weather Resistance: IP65
Ring Tone: Shrill warble tone 80 dBA @ 1 meter typical
Hook switch: Electronic / magnetic with no visible moving parts
M.T.B.F.: in excess of 40,000 hours using
Dimensions & Weight : 248 x 185 x 129 mm, 2.5 Kg
Packing: Carton 340 x 235 x 165 mm , 3.5 Kg

Analog Specifications

Dialing : MF (Tone)
Power Supply: from telephone line
Lightning / Transients : Protective to ITU-T k.21 enhanced levels
Programming : can be programmed as an auto-dial phone

SIP / VoIP Specifications

Adaptor input : 100-240 VAC 55-60Hz , Output: 5V/1A
Port: WAN: 10/100Base - TRJ-45 for LAN, Auto MDIX - LAN: 10/100Base - TRJ-45 for PC, Auto MDIX
Power Consumption : Idle: 1.5W / Active : 1.8 W
Main Chip : Broadcom
Voice Feature: Support 2 lines SIP, SIP 2.0 (RFC32610)
Codec: .711A/u, G.7231 high/low. G.729, G.722, G.729
Echo Cancellation: Support G.168 and hand-free can support 96 ms Full Duplex: Supported
Support: SIP support, SIP Domain, SIP authentication (non basic, MD5) DNS name of server, peer to peer
 SIP Support 2 servers, user can through each server to calling in and out
Network Features :
 - WAN/LAM: support Bridge Mode
 - Support PPPoE for xDSL
 - Support VLAN
 - Support Stun penetration
 - Support DHCP get IP on WAN port

GSM / 3G Specifications

Standard SIM card
 - **GSM :** GSM 850/900/1800/1900 MHz
 - **3G:** WCDMA 850/1900/2100 MHz
Adapter Input : 7.4 V- 12 V DC
Power Consumption : Idle: 75mA / Active :160 mA

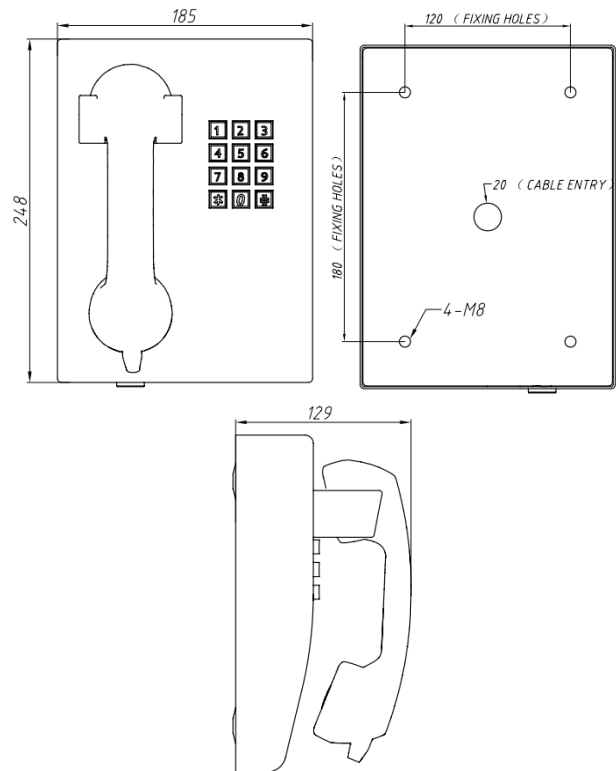

Ordering Information:

Part Number	Description
TK-206-FK-ANG	Analogue Hotline Flush Mounting Telephone
TK-206-FK-SIP	SIP / VoIP Hotline Flush Mounting
TK-206-FK-GSM	GSM Hotline Flush Mounting Telephone
TK-206-FK-3G	3G Hotline Flush Mounting Telephone

Please send your inquiries to: info@tashkoo.com

Information provided is subject to change without notice

Speed Dial Wall Mounting Telephone



- Robust housing, constructed of stainless steel
- Weather proof protection IP65
- Vandal resistant metal button
- Hands free operation
- Wall mounting, simple installation
- Single , dual or triple button with remote programming
- Phone line powered (Analogue)
- External power supply or PoE (SIP-VoIP)
- RJ45 port for SIP phone
- 4 X Tamper proof screws for faceplate mounting
- CE , FCC compliant

TASHKOO offered weatherproof telephones are designed to meet the needs of client who experience loss through vandalism. Ideal for parking lots, prisons, railway/metro platforms, hospitals, police stations, ATM machines, stadiums, outside building etc.

Housed in cold rolled steel box and manufactured to a high standard, these telephones offer increased resistance to vandalism, and ensure that the primary function of communications is maintained at all times. Extremely easy to install. The cable entrance is on the back of the phone to prevent from artificial damage, while the keypad is weather and vandal resistant.

Units are available as multi or single button autodiallers providing on/dial/off functions. These models are programmable with numbers up to 16 digits. A microphone muting facility guards against unauthorised calls made with a portable MF tone pad



Technical Specifications

- Casing Material :** Cold rolled Steel body
- Colors:** yellow , red & grey . other colors to special order
- Handset Material:** No Handset
- Keypad:** With built-in mini keypad for program number
- Temperature:** Operating: -30°C to +65°C - Storing: -40°C to +75°C
- Weather Resistance:** IP65
- Ring Tone:** Shrill warble tone 80 dBA @ 1 meter typical
- Hook switch:** N/A
- M.T.B.F.:** in excess of 40,000 hours using
- Dimensions & Weight (Type 1):** 210 x 140 x 50 mm, 2.7 Kg
- Dimensions & Weight (Type 2):** 260 x 235 x 165 mm, 2.7 Kg
- Packing:** Carton 340 x 235 x 165 mm , 3.5 Kg

Analog Specifications

- Dialing :** MF (Tone)
- Power Supply:** from telephone line
- Lightning / Transients :** Protective to ITU-T k.21 enhanced levels
- Programming :** can be programmed as an auto-dial phone

SIP / VoIP Specifications

- Adaptor input :** 100-240 VAC 55-60Hz , Output: 5V/1A
- Port:** WAN: 10/100Base - TRJ-45 for LAN, Auto MDIX - LAN: 10/100Base - TRJ-45 for PC, Auto MDIX
- Power Consumption :** Idle: 1.5W / Active : 1.8 W
- Main Chip :** Broadcom
- Voice Feature:** Support 2 lines SIP, SIP 2.0 (RFC32610)
- Codec:** .711A/u, G.7231 high/low. G.729, G.722, G.729
- Echo Cancellation:** Support G.168 and hand-free can support 96 ms
- Full Duplex:** Supported
- Support:** SIP support, SIP Domain, SIP authentication (non basic, MD5) DNS name of server, peer to peer
- SIP Support 2 servers, user can through each server to calling in and out

Network Features :

- WAN/LAM: support Bridge Mode
- Support PPPoE for xDSL
- Support VLAN
- Support Stun penetration
- Support DHCP get IP on WAN port

GSM / 3G Specifications

- Standard SIM card
- GSM :** GSM 850/900/1800/1900 MHz
- 3G:** WCDMA 850/1900/2100 MHz
- Adapter Input :** 7.4 V- 12 V DC
- Power Consumption :** Idle: 75mA / Active :160 mA

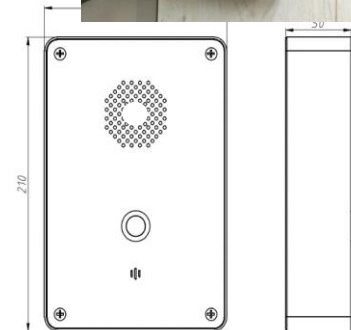
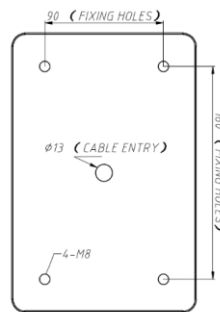

Type 1

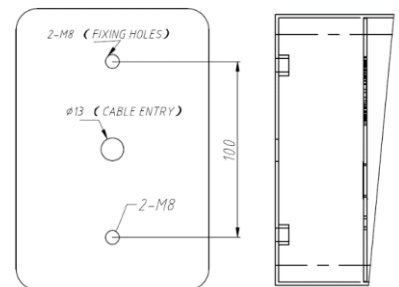
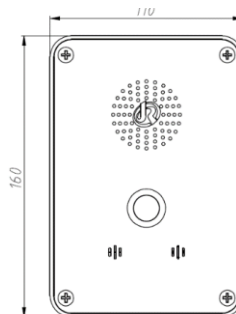

Type 2

Ordering Information:

Part Number	Description
TK-301-WM-1B-ANG	Analogue Type 1, Flush Mounting Telephone
TK-301-WM-1B-SIP	SIP / VoIP Type 1, Flush Mounting
TK-301-WM-1B-GSM	GSM Hotline Type 1, Mounting Telephone
TK-301-WM-1B-3G	3G Hotline Type 1, Mounting Telephone
TK-304-WM-1B-ANG	Analogue Type 1, Flush Mounting Telephone
TK-304-WM-1B-SIP	SIP / VoIP Type 1, Flush Mounting
TK-304-WM-1B-GSM	GSM Type 1, Flush Mounting Telephone
TK-304-WM-1B-3G	3G Type 1, Flush Mounting Telephone

Note: Please use 2B for two button and 3B for three button versions

Please send your inquiries to: info@tashkoo.com

Information provided is subject to change without notice

Speed Dial Wall Mounting Telephone



- Robust housing, constructed of stainless steel
- Weather proof protection IP65
- Vandal resistant metal button(s)
- Hands free operation
- Wall mounting, simple installation
- Single , dual or triple button options, remote programming
- Phone line powered (Analogue)
- External power supply or PoE (SIP-VoIP)
- RJ45 port for SIP phone
- 4 X Tamper proof screws for faceplate mounting
- CE , FCC compliant

TASHKOO offered weatherproof telephones are designed to meet the needs of client who experience loss through vandalism. Ideal for parking lots, prisons, railway/metro platforms, hospitals, police stations, ATM machines, stadiums, outside building etc.

Housed in cold rolled steel box and manufactured to a high standard, these telephones offer increased resistance to vandalism, and ensure that the primary function of communications is maintained at all times. Extremely easy to install. The cable entrance is on the back of the phone to prevent from artificial damage, while the keypad is weather and vandal resistant.

Units are available as multi or single button autodiallers providing on/dial/off functions. These models are programmable with numbers up to 16 digits. A microphone muting facility guards against un-authorized calls made with a portable MF tone pad

Technical Specifications

- Casing Material :** Cold rolled Steel body
- Colors:** yellow , red & grey . other colors to special order
- Handset Material:** No Handset
- Keypad:** With built-in mini keypad for program number
- Temperature:** Operating: -30°C to +65°C - Storing: -40°C to +75°C
- Weather Resistance:** IP65
- Ringing Tone:** Shrill warble tone 80 dBA @ 1 meter typical
- Hook switch:** N/A
- M.T.B.F.:** in excess of 40,000 hours using
- Dimensions & Weight :** 210 x 140 x 50 mm, 2.7 Kg
- Packing:** Carton 340 x 235 x 165 mm , 3.5 Kg

Analog Specifications

- Dialing :** MF (Tone)
- Power Supply:** from telephone line
- Lightning / Transients :** Protective to ITU-T k.21 enhanced levels
- Programming :** can be programmed as an auto-dial phone

SIP / VoIP Specifications

- Adaptor input :** 100-240 VAC 55-60Hz , Output: 5V/1A
- Port:** WAN: 10/100Base - TRJ-45 for LAN, Auto MDIX - LAN: 10/100Base - TRJ-45 for PC, Auto MDIX
- Power Consumption :** Idle: 1.5W / Active : 1.8 W
- Main Chip :** Broadcom
- Voice Feature:** Support 2 lines SIP, SIP 2.0 (RFC32610)
- Codec:** .711A/u, G.7231 high/low, G.729, G.722, G.729
- Echo Cancellation:** Support G.168 and hand-free can support 96 ms Full Duplex: Supported
- Support:** SIP support, SIP Domain, SIP authentication (non basic, MD5) DNS name of server, peer to peer SIP Support 2 servers, user can through each server to calling in and out
- Network Features :**
 - WAN/LAM: support Bridge Mode
 - Support PPPoE for xDSL
 - Support VLAN
 - Support Stun penetration
 - Support DHCP get IP on WAN port

GSM / 3G Specifications

- Standard SIM card
- GSM :** GSM 850/900/1800/1900 MHz
- 3G:** WCDMA 850/1900/2100 MHz
- Adapter Input :** 7.4 V- 12 V DC
- Power Consumption :** Idle: 75mA / Active :160 mA

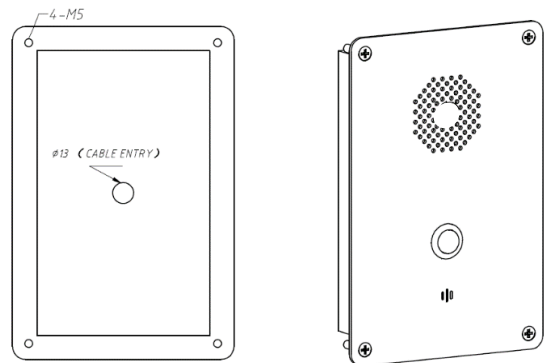
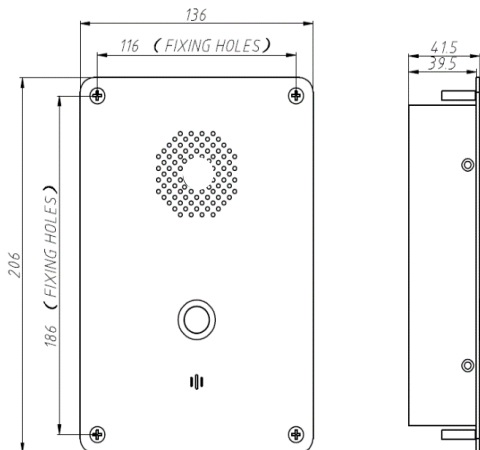

Ordering Information:

Part Number	Description
TK-301-FM-1B-ANG	Analogue Hotline Flush Mounting Telephone
TK-301-FM-1B-SIP	SIP / VoIP Hotline Flush Mounting
TK-301-FM-1B-GSM	GSM Hotline Flush Mounting Telephone
TK-301-FM-1B-3G	3G Hotline Flush Mounting Telephone

Note: Please use 2B for two button and 3B for three button versions

Please send your inquiries to: info@tashkoo.com

Information provided is subject to change without notice

Wall Mounting Help Point



- Robust housing, constructed of cold rolled steel
- Vandal resistant metal button
- Weather proof protection IP65
- Hands free operation
- Wall mounting, simple installation
- Single or Dual button autodial options, remote programming
- Phone line (Analogue) or 12V DC powered
- RJ45 port for SIP phone
- 4 X Tamper proof screws for faceplate mounting
- CE , FCC compliant

TASHKOO offered weatherproof telephones are designed to meet the needs of client who experience loss through vandalism. Ideal for parking lots, prisons, railway/metro platforms, hospitals, police stations, ATM machines, stadiums, outside building etc.

Housed in cold rolled steel box and manufactured to a high standard, these telephones offer increased resistance to vandalism, and ensure that the primary function of communications is maintained at all times. Extremely easy to install. The cable entrance is on the back of the phone to prevent from artificial damage, while the keypad is weather and vandal resistant.

Units are available as multi or single button autodiallers providing on/dial/off functions. These models are programmable with numbers up to 16 digits. A microphone muting facility guards against un-authorized calls made with a portable MF tone pad

Technical Specifications

Casing Material : Cold rolled Steel body
Colors: yellow , red & grey . other colors to special order
Handset Material: No Handset
Keypad: N/A
Temperature: Operating: -30°C to +65°C - Storing: -40°C to +75°C
Weather Resistance: IP65
Ringing Tone: Shrill warble tone 80 dBA @ 1 meter typical
Hook switch: N/A
M.T.B.F.: in excess of 50,000 hours using
Dimensions & Weight : 170 x 130 x60 mm, 0.8 Kg
Packing: Carton 200 x 140 x 100 mm , 1 Kg

Analog Specifications

Dialing : MF (Tone)
Power Supply: from telephone line
Lightning / Transients : Protective to ITU-T k.21 enhanced levels
Programming : can be programmed as an auto-dial phone

SIP / VoIP Specifications

Adaptor input : 100-240 VAC 55-60Hz , Output: 5V/1A
Port: WAN: 10/100Base - TRJ-45 for LAN, Auto MDIX - LAN: 10/100Base - TRJ-45 for PC, Auto MDIX
Power Consumption : Idle: 1.5W / Active : 1.8 W
Main Chip : Broadcom
Voice Feature: Support 2 lines SIP, SIP 2.0 (RFC32610)
Codec: .711A/u, G.7231 high/low, G.729, G.722, G.729
Echo Cancellation: Support G.168 and hand-free can support 96 ms Full Duplex: Supported
Support: SIP support, SIP Domain, SIP authentication (non basic, MD5) DNS name of server, peer to peer
SIP Support 2 servers, user can through each server to calling in and out
Network Features :
 - WAN/LAM: support Bridge Mode
 - Support PPPoE for xDSL
 - Support VLAN
 - Support Stun penetration
 - Support DHCP get IP on WAN port

GSM / 3G Specifications

Standard SIM card
- GSM : GSM 850/900/1800/1900 MHz
- 3G: WCDMA 850/1900/2100 MHz
Adapter Input : 7.4 V- 12 V DC
Power Consumption : Idle: 75mA / Active :160 mA

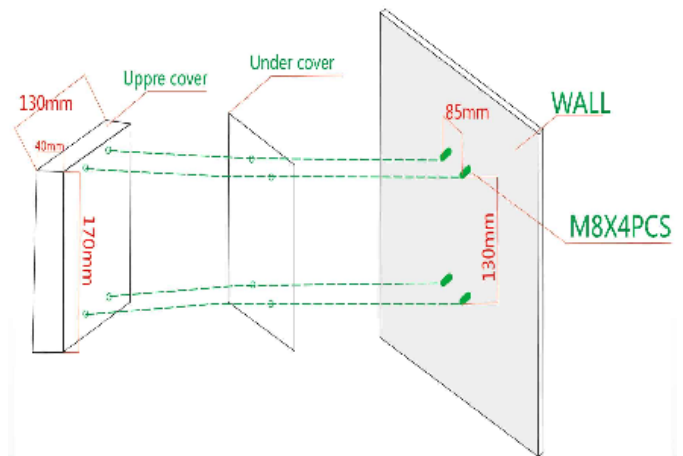

Ordering Information:

Part Number	Description
TK-313-1B-WM-ANG	Analogue Wall Mounting Help point
TK-313-1B-WM-SIP	SIP / VoIP Wall Mounting Help point
TK-313-1B-WM-GSM	GSM Hotline Wall Mounting Help point
TK-313-1B-WM-3G	3G Hotline Wall Mounting Help point

Please send your inquiries to: info@tashkoo.com

Information provided is subject to change without notice

Flush Mounting Help Point



- Robust housing, constructed of cold rolled steel
- Vandal resistant metal button
- Weather proof protection IP65
- Hands free operation
- Wall mounting, simple installation
- Single or Dual button autodial options, remote programming
- Phone line (Analogue) or 12V DC powered
- RJ45 port for SIP phone
- 4 X Tamper proof screws for faceplate mounting
- CE , FCC compliant

TASHKOO offered weatherproof telephones are designed to meet the needs of client who experience loss through vandalism. Ideal for parking lots, prisons, railway/metro platforms, hospitals, police stations, ATM machines, stadiums, outside building etc.

Housed in cold rolled steel box and manufactured to a high standard, these telephones offer increased resistance to vandalism, and ensure that the primary function of communications is maintained at all times. Extremely easy to install. The cable entrance is on the back of the phone to prevent from artificial damage, while the keypad is weather and vandal resistant.

Units are available as multi or single button autodiallers providing on/dial/off functions. These models are programmable with numbers up to 16 digits. A microphone muting facility guards against un-authorized calls made with a portable MF tone pad

Technical Specifications

Casing Material : Cold rolled Steel body
Colors: yellow , red & grey . other colors to special order
Handset Material: No Handset
Keypad: N/A
Temperature: Operating: -30°C to +65°C - Storing: -40°C to +75°C
Weather Resistance: IP65
Ringing Tone: Shrill warble tone 80 dBA @ 1 meter typical
Hook switch: N/A
M.T.B.F.: in excess of 50,000 hours using
Dimensions & Weight : 170 x 130 x60 mm, 0.8 Kg
Packing: Carton 200 x 140 x 100 mm , 1 Kg

Analog Specifications

Dialing : MF (Tone)
Power Supply: from telephone line
Lightning / Transients : Protective to ITU-T k.21 enhanced levels
Programming : can be programmed as an auto-dial phone

SIP / VoIP Specifications

Adaptor input : 100-240 VAC 55-60Hz , Output: 5V/1A
Port: WAN: 10/100Base - TRJ-45 for LAN, Auto MDIX - LAN: 10/100Base - TRJ-45 for PC, Auto MDIX
Power Consumption : Idle: 1.5W / Active : 1.8 W
Main Chip : Broadcom
Voice Feature: Support 2 lines SIP, SIP 2.0 (RFC32610)
Codec: .711A/u, G.7231 high/low, G.729, G.722, G.729
Echo Cancellation: Support G.168 and hand-free can support 96 ms
Full Duplex: Supported
Support: SIP support, SIP Domain, SIP authentication (non basic, MD5)
DNS name of server, peer to peer
SIP Support 2 servers, user can through each server to calling in and out
Network Features :
 - WAN/LAM: support Bridge Mode
 - Support PPPoE for xDSL
 - Support VLAN
 - Support Stun penetration
 - Support DHCP get IP on WAN port

GSM / 3G Specifications

Standard SIM card
- GSM : GSM 850/900/1800/1900 MHz
- 3G: WCDMA 850/1900/2100 MHz
Adapter Input : 7.4 V- 12 V DC
Power Consumption : Idle: 75mA / Active :160 mA

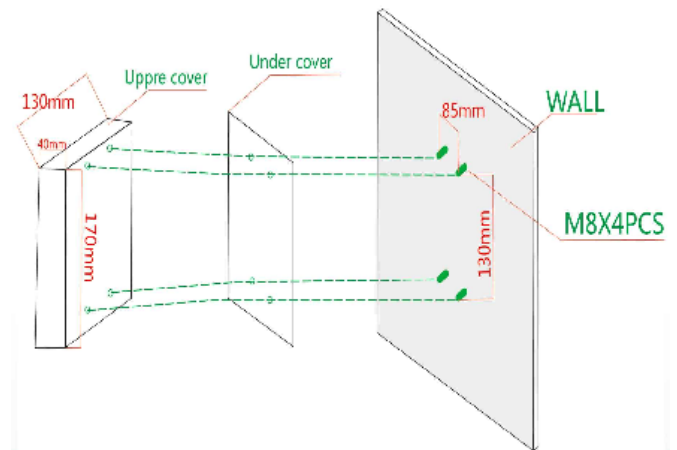

Ordering Information:

Part Number	Description
TK-314-1B-FM-ANG	Analogue Wall Mounting Help point
TK-314-1B-FM-SIP	SIP / VoIP Wall Mounting Help point
TK-314-1B-FM-GSM	GSM Hotline Wall Mounting Help point
TK-314-1B-FM-3G	3G Hotline Wall Mounting Help point

Please send your inquiries to: info@tashkoo.com

Information provided is subject to change without notice

Emergency Roadside Phone



- Vandal resistant metal button
- Robust housing, constructed of cold rolled steel
- Weather proof protection IP65
- Hands free operation
- Wall mounting, simple installation
- Single or Dual button autodial options, remote programming
- Phone line (Analogue) or 12V DC powered
- RJ45 port for SIP phone
- 4 X Tamper proof screws for faceplate mounting
- CE , FCC compliant

TASHKOO offered weatherproof telephones are designed to meet the needs of client who experience loss through vandalism. Ideal for parking lots, prisons, railway/metro platforms, hospitals, police stations, ATM machines, stadiums, outside building etc.

Housed in cold rolled steel box and manufactured to a high standard, these telephones offer increased resistance to vandalism, and ensure that the primary function of communications is maintained at all times. Extremely easy to install. The cable entrance is on the back of the phone to prevent from artificial damage, while the keypad is weather and vandal resistant.



Technical Specifications

Casing Material : Cold rolled Steel body
Colors: yellow , red & grey . other colors to special order
Handset Material: No Handset
Keypad: N/A
Temperature: Operating: -30°C to +65°C - Storing: -40°C to +75°C
Weather Resistance: IP65
Ringing Tone: Shrill warble tone 80 dBA @ 1 meter typical
Hook switch: N/A
M.T.B.F.: in excess of 50,000 hours using
Dimensions & Weight : 339 x 146 x 126 mm, 5 Kg
Packing: Carton 200 x 300 x 440 mm , 6 Kg

Analog Specifications

Dialing : MF (Tone)
Power Supply: from telephone line
Lightning / Transients : Protective to ITU-T k.21 enhanced levels
Programming : can be programmed as an auto-dial phone

SIP / VoIP Specifications

Adaptor input : 100-240 VAC 55-60Hz , Output: 5V/1A
Port: WAN: 10/100Base - TRJ-45 for LAN, Auto MDIX - LAN: 10/100Base - TRJ-45 for PC, Auto MDIX
Power Consumption : Idle: 1.5W / Active : 1.8 W
Main Chip : Broadcom
Voice Feature: Support 2 lines SIP, SIP 2.0 (RFC32610)
Codec: .711A/u, G.7231 high/low. G.729, G.722, G.729
Echo Cancellation: Support G.168 and hand-free can support 96 ms
Full Duplex: Supported
Support: SIP support, SIP Domain, SIP authentication (non basic, MD5)
DNS name of server, peer to peer
SIP Support 2 servers, user can through each server to calling in and out
Network Features :
 - WAN/LAM: support Bridge Mode
 - Support PPPoE for xDSL
 - Support VLAN
 - Support Stun penetration
 - Support DHCP get IP on WAN port

GSM / 3G Specifications

Standard SIM card
- GSM : GSM 850/900/1800/1900 MHz
- 3G: WCDMA 850/1900/2100 MHz
Adapter Input : 7.4 V- 12 V DC
Power Consumption : Idle: 75mA / Active :160 mA

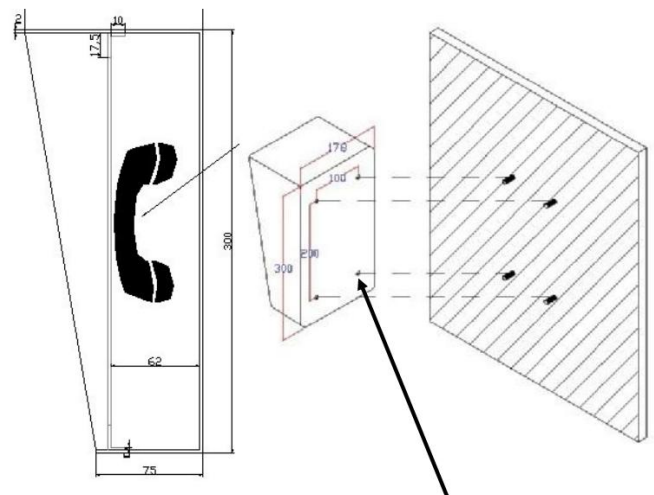

Ordering Information:

Part Number	Description
TK-306-1B-FM-ANG	Analogue Wall Mounting Help point
TK-306-1B-FM-SIP	SIP / VoIP Wall Mounting Help point
TK-306-1B-FM-GSM	GSM Hotline Wall Mounting Help point
TK-306-1B-FM-3G	3G Hotline Wall Mounting Help point

Please send your inquiries to: info@tashkoo.com

Information provided is subject to change without notice

Emergency Post Mounting Roadside Phone

- Solar panels and batteries are sized according to the installation location. A charger, batteries and other equipment mount inside the tower
- Attention-getting LED Blue Light is included and mounted atop the unit. The LED Blue Light is continuously lit and flashes for duration of a call when "EMERGENCY" button is pressed to draw attention to the unit.
- LED Blue Light is housed in a protective polycarbonate housing
- Emergency Phone faceplate is made of brushed stainless steel with security screw
- Vandal-resistant structure and coating designed to resist extreme weather conditions
- A variety of signage, graphics and color choices are available
- ADA-compliant

TASHKOO offered Emergency Phone Tower is an ideal security solution for remote and high-risk areas. Standing over nine feet tall, this vandal-resistant tower serves as a great deterrent to crime. An always-lit LED Blue Light mounted atop the tower provides high visibility and gives passers-by a sense of security. Patrons can call emergency personnel with a simple push of a button. At the same time, the LED Blue Light begins to flash, attracting attention to the location. The Emergency Phone faceplate is illuminated at all times for clear visibility during the night.

The Emergency Phone Tower offer greater deployment flexibility with wireless, solar, surveillance and day/night charge options. They are often used at university and college campuses parking facilities, shopping malls, medical centers, industrial campuses, transit facilities and remote locations where local power is not available.

Technical Specifications

Built-in auto-dialer 2-way hands-free communication, with built-in speaker and microphone, Auto-answer allows security to monitor and initiate calls with Emergency Phone Vandal resistant brushed stainless steel faceplate and metal button, Circuit boards are perfectly coated for water protection.

Casing Material : 0.25 in. Steel,

Coating: High-gloss, multi-layer, corrosion-inhibitive system with resistance to graffiti protection

Color: Safety Red is standard. Available in custom colors

Signage: 3.25 in. high reflective white "EMERGENCY" lettering with wide-angle visibility is standard, Available in custom colors, lettering and graphics

Lighting: LED Blue Light, 209 lumens peak, 78 flashes per minute, 70% of initial lumens after 50,000 hours of operation

Power: 9.0 Watt, 12-24 V DC

Mounting: Mounts into concrete foundation using included hardware (shipped in advance). Mounting options available for pre-poured parking decks.

Warranty: 5-year warranty on tower , 2- year on electronics

Dimensions & Weight : 305 x 254 x 3249 mm, 135 Kg (empty tower)

Analog Specifications

Dialing : MF (Tone)

Power Supply: from telephone line

Lightning / Transients : Protective to ITU-T k.21 enhanced levels

Programming : can be programmed as an auto-dial phone

SIP / VoIP Specifications

Adaptor input : 100-240 VAC 55-60Hz , Output: 5V/1A

Port: WAN: 10/100Base - TRJ-45 for LAN, Auto MDIX - LAN: 10/100Base - TRJ-45 for PC, Auto MDIX

Power Consumption : Idle: 1.5W / Active : 1.8 W

Main Chip : Broadcom

Voice Feature: Support 2 lines SIP, SIP 2.0 (RFC32610)

Codec: .711A/u, G.7231 high/low. G.729, G.722, G.729

Echo Cancellation: Support G.168 and hand-free can support 96 ms

Full Duplex: Supported

Support: SIP support, SIP Domain, SIP authentication (non basic, MD5)

DNS name of server, peer to peer

SIP Support 2 servers, user can through each server to calling in and out

Network Features :

- WAN/LAM: support Bridge Mode
- Support PPPoE for xDSL
- Support VLAN
- Support Stun penetration
- Support DHCP get IP on WAN port

GSM / 3G Specifications

Standard SIM card

- **GSM :** GSM 850/900/1800/1900 MHz

- **3G:** WCDMA 850/1900/2100 MHz

Adapter Input : 7.4 V- 12 V DC

Power Consumption : Idle: 75mA / Active :160 mA

Information provided is subject to change without notice

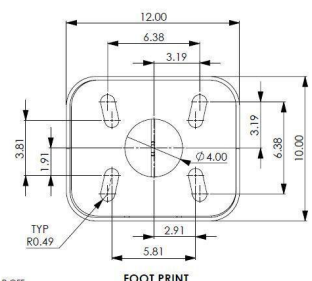
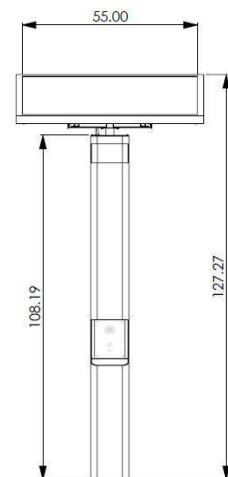

For ordering Information:

Please contact:

info@tashkoo.com

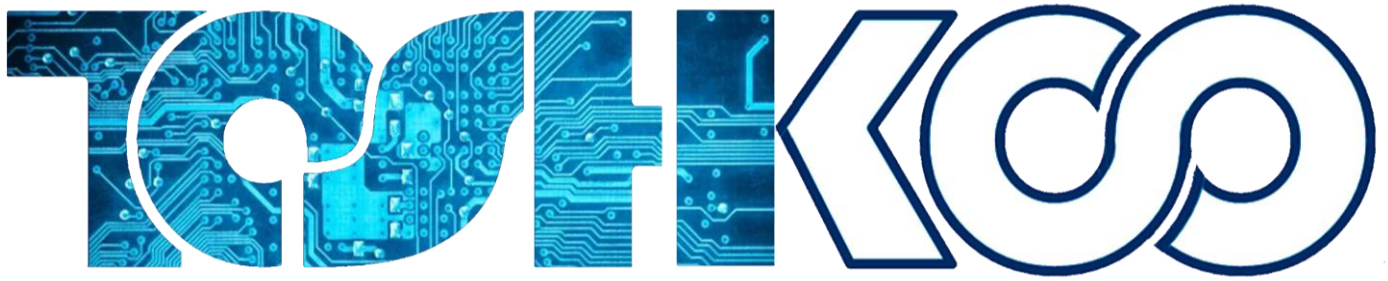

TASHKOO offers a range of weatherproof analogue, VoIP-SIP and GSM (GSM-R) telephones designed for arduous environment. Open protocol hardware gives telecoms designers the flexibility to furnish an entire estate with the same hardware, but with a choice of connectivity for each location. This allows projects to be deployed efficiently and cost-effectively, Our offered standard telephones combine weather and vandal resistance with bespoke acoustic design. But where we really excel is our flexibility when you need a customized product.

The successful cooperation with thousands of customers all over the world and the supports to hundreds of projects have made our offered products manufacturer a reliable and popular supplier of industrial phones and phone accessories. The main products include weatherproof telephones, inmate phones, emergency phones, elevator phones and telephone kits as well

The offered products are in compliance with:

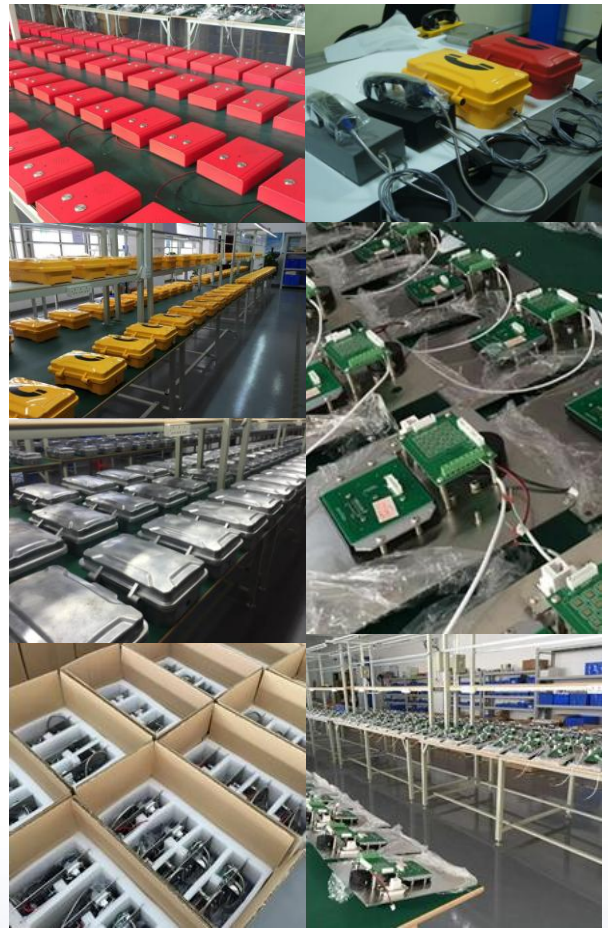

TASHKOO is a British specialist company in the field of Electrical, Telecommunications & Control systems and solutions. TASHKOO engineers and professionals have over 20 years of experiences in turn-key projects for manufacturing, systems integrations, installations and commissioning of advanced technology products for electrical, power line, telecommunications and control systems and solutions.

TASHKOO engineers have many years of successful experiences to supply customers with the most cost effective solutions based on latest technology products from the world leading manufacturers. TASHKOO is experienced in providing complete solutions for complex requirements.

TASHKOO can offer value added services which will save your money, resources, and headaches and smoothly get your electrical, telecommunications & control systems up and running in a shorter time. We can simply customize our offers to suit your technical requirements.



TASHKOO Limited

Hertfordshire
United Kingdom
Tel: +44 (0) 1923 518589

Email: info@tashkoo.com

www.tashkoo.com